

THE SECOND PART:
CONCERNING THE PRINCIPLES
OF THE MOTION OF FLUIDS

E 396

Novi commentarii academiae scientiarum Petropolitanae 14 (1769): I, 1770, p. 270-386

CHAPTER I

CONSIDERATION OF THE MOTION OF FLUIDS IN GENERAL

PROBLEM 17

1. *If a mass of fluid may be moving in some manner, to establish the principles, from which its state and motion may be known conveniently at some time, and which may be applied according to a calculation.*

SOLUTION

Individual elements of the fluid may be referred to the three axes OA , OB and OC (Fig. 22) fixed normal to each other, thus so that the position of any element placed at Z will be determined by the three coordinates parallel to the these axes, which shall be $OX = x$, $XY = y$ and $YZ = z$: and since the fluid shall be constituted to be in motion, we will consider that element, which now will be arriving at the point Z , because now, after having flowed for a certain time interval $= t$, since with the passage of time more and still more different fluid elements will have passed through the same point Z . Now for the present state

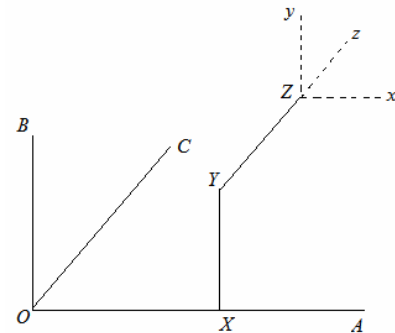

of the fluid requiring to be known, if its density shall be capable of variation, initially the density of the fluid at the point Z is required to be defined, which we will designate by the letter q , since not only may it be able to be different for different positions of the point Z , but also for differences in the time, this quantity q will be required to be considered as a function of the four variables x , y , z and t , in which if t may be written for the proposed time, truly x , y and z may be written for these three coordinates OX , XY , YZ , which agree for Z , so that the density of the fluid at Z will be obtained for the proposed time. But if the density of the fluid shall be the same everywhere and always, the letter q will denote a constant quantity.

In the second place it will be required to know also the pressure at the place Z , which may be expressed by the height $= p$, which evidently shall be attributed to a column composed from a homogeneous material, of which the density to be constant $= 1$, so that the weight of that may be equal to the pressure impressed on the base, and for this reason

that density q shall be required to be measured always with respect to this density of unity. Therefore since both the height for the various places as well as the times may be different, also p must be treated as a function of the four variables x, y, z and t .

Thirdly, if the fluid shall be subjected to the action of forces such as gravity and other similar forces, it will be permitted to resolve these always along the three directions of the coordinates. Therefore these accelerating forces acting on the element placed at Z shall be along the direction $Zx = P$, along the direction $Zy = Q$ and following the direction $Zz = R$, with the natural force of gravity put $= 1$. These forces, if they shall be variable, are accustomed to depend only on the location of the point Z , and truly not on the time t .

In the fourth place, especially for a known motion, it is necessary to know the motion of each element for any time, which motion is resolved most conveniently along the directions of the three axes. Therefore for the time $= t$, the speed of the element at Z moving along the direction $Zx = u$, along the direction $Zy = v$ and along $Zz = w$, which three speeds therefore must be considered as functions of the four variables x, y, z and t . Where it is readily apparent the calculation can be prepared thus, so that the time t is expressed in seconds, and moreover the speeds u, v, w by the distances traversed in one second.

COROLLARY 1

2. Therefore the state and motion of the known fluid is contained perfectly by these four headings, which we have set forth, evidently with the density, pressure, and with the disturbing forces and the three speeds of each element, which if we may wish to assign to some time, we will have perfect knowledge of the whole motion.

COROLLARY 2

3. Indeed the forces, by which the fluid may be disturbed, besides are always given, nor will these depend on the motion: thus, even if the motion shall be unknown, the forces P, Q, R , which are acting on the individual elements, are referred to as known quantities, and from these mainly the remaining headings are allowed to be determined.

COROLLARY 3

4. When the fluid is homogeneous and its density is not subject to any objectionable variation, the quantity q will be given also, but if it may be either heterogeneous, or it may have some small density variation, generally it is necessary that for the enduring motion at some point Z , the changing density of the particles there shall require to be investigated.

COROLLARY 4

5. Therefore the whole theory of motion of fluids reverts to this, in order that for the given nature of the fluid and for the disturbing forces acting, the quantities q, p, u, v, w may be defined and expressed thus by the four variables x, y, z and t , so that the values of these may be able to be assigned both for some point Z , as well as for some time t .

SCHOLIUM 1

6. Since these quantities q, p, u, v, w must be treated as functions of these four variables x, y, z and t , the differential of each taken in general thus will be expressed :

$$dq = dx\left(\frac{dq}{dx}\right) + dy\left(\frac{dq}{dy}\right) + dz\left(\frac{dq}{dz}\right) + dt\left(\frac{dq}{dt}\right)$$

of which the forms of the first three parts show the increment of the density, which now may be put in place at Z , $= q$, while in the time remaining t we have passed to another point close to Z , the position of which is determined by these three coordinates $x + dx, y + dy, z + dz$, and thus it is understood, how with the time t taken as constant for some instant through the whole mass of the fluid, the density of the individual points themselves shall be obtained, which is required to be understood in a similar manner for the pressure, and for the three speeds of the individual elements, and this indeed is evident from the nature of differentiation itself. But if, with the coordinates remaining x, y and z , and with the same time t with its differential increased by dt , the density now will become $q + dt\left(\frac{dq}{dt}\right)$, but which by no means will present a variation in the density of that element of fluid in the small time dt , which was adhering together at Z , to the extent that the formula has not been attended to well enough, for that formula will indicate rather, the density of another element which finally will pass through the point Z in the elapsed increment of the time dt . But when we may wish to define the variation in the density of this element of fluid in the time increment dt , which will be moving through Z and of which the density was $= q$, before all others, we will have to consider, where this element will be adhering together after the time dt , which if it may be indicated by these varied coordinates $x + dx, y + dy, z + dz$, truly the increment of the density will become

$$dx\left(\frac{dq}{dx}\right) + dy\left(\frac{dq}{dy}\right) + dz\left(\frac{dq}{dz}\right) + dt\left(\frac{dq}{dt}\right).$$

And this same caution is required to be used, if we may wish to determine either the pressure or the motion of the three speeds u, v, w of this same fluid element, which now may be moving about Z , in the elapsed time increment dt . Which caution therefore is all the more necessary and to be used with all the care demanded, so that we may be able to cut down the gravest errors on account of our lack of attention due to our neglect.

SCHOLIUM 2

7. Again it is necessary generally for the motion of the fluid requiring to be known, to know the motion of its elements, and it suffices at least, as is accustomed to happen in solid bodies, to have investigated only the motion of a few points. Clearly in the motion of rigid solid bodies, and the motion of three points not situated in the direction of the motion of the body may become known, then at once the motion of all the remaining

points of the body is defined; and if a flexible body shall be provided, indeed the motions more points is required for the motion of the whole body to be defined, yet the number of these is finite always. But in fluids the individual elements can be carried by the motion, thus so that, even if we have investigated the motion of a thousand particles, yet the whole motion will not be determined from these. Nor yet the motion of all the elements thus by no means are agreed to depend on each other mutually, even if indeed the density of the fluid may be allowed to undergo no change, it is evident the individual particles thus are not able to flow together blindly, so that they may be scattered into a greater volume, or may be forced into a smaller one, from which a certain condition between the motion of the particles is established. But even if the fluid shall be capable of condensation and rarefaction, yet such a change cannot happen without that being had with respect of the pressure, from which on account of the pressure, all the motions of all the particles may be bounded by a certain law. But this limitation in the theory of the motion of fluids constitutes the first chapter so that from that it is observed to be deduced readily, that the density as well as the motion of each point may be investigated.

SCHOLIUM 3

8. These four chapters, from which we have said a perfect understanding of the motion of fluids to be contained, perhaps will be seen not yet to suffice for this goal, because it is necessary for many other circumstances to be attended to, such as if the fluid shall be enclosed by a vessel, through which it can neither flow through nor from which it may flow out, also it will be required to know for any time, to what extent it may be spread out in the vessel, and likewise the shape of the vessel will be required to be considered properly: where if there shall be an opening in a part of the fluid, where clearly the pressure were zero, also these circumstances will be entirely necessary for determining further motion. Truly the first four chapters alone presented here suffice to hold the exposition for the entire motion, with the differential equations included, in which the force of the source of the motion is presented chiefly. Moreover with these equations found, when it is required to integrate these, then at last all these circumstances will be introduced into the computation, and the analysis thus will be taken to be adapted always for all the cases, so that from all these conditions, whatever the circumstances they prescribe, always may be able to be satisfied perfectly.

PROBLEM 18

9. *For the given speeds u , v and w , by which the individual elements of the fluid are moved, to investigate the displacement of each and every molecule of the fluid made in the infinitely small time dt .*

SOLUTION

To the molecule (Fig. 23) whose translation we seek, we may attribute the figure of a triangular pyramid $ZLMN$, for the four angles of which there shall be the three coordinates : [Here the word 'molecule' is taken to mean a small mass.]

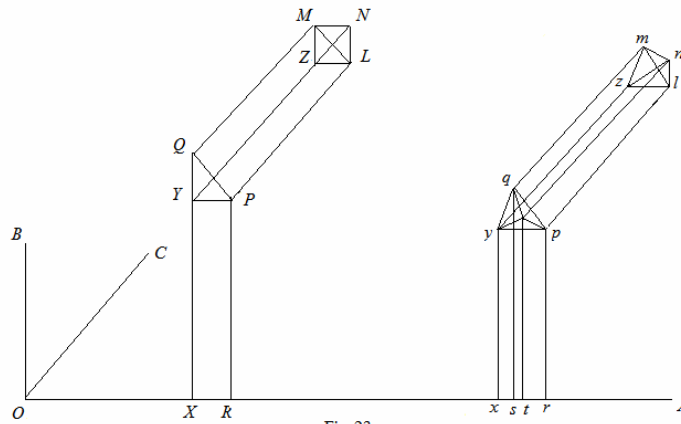

Fig. 23

$$\begin{aligned}
 \text{For } Z \quad OX = x, \quad XY = y, \quad YZ = z \\
 \text{For } L \quad OR = x + dx, \quad RP = y, \quad PL = z \\
 \text{For } M \quad OX = x, \quad XY = y + dy, \quad QM = z \\
 \text{For } N \quad OX = x, \quad XY = y, \quad YN = z + dz.
 \end{aligned}$$

Since now for the point Z the speeds along directions parallel to the three axes u, v, w shall be functions of the four variables x, y, z and t , hence for the individual angles these speeds themselves thus will be had

	speed	speed	speed
For Z, along	$OA = u,$	along $OB = v,$	along $OC = w$
For L "	$OA = u + dx \left(\frac{du}{dx} \right),$	" $OB = v + dx \left(\frac{dv}{dx} \right),$	" $OC = w + dx \left(\frac{dw}{dx} \right)$
For M "	$OA = u + dy \left(\frac{du}{dy} \right),$	" $OB = v + dy \left(\frac{dv}{dy} \right),$	" $OC = w + dy \left(\frac{dw}{dy} \right)$
For N "	$OA = u + dz \left(\frac{du}{dz} \right),$	" $OB = v + dz \left(\frac{dv}{dz} \right),$	" $OC = w + dz \left(\frac{dw}{dz} \right)$

Therefore, by these speeds in the time increment dt , these four points Z, L, M, N will be transferred to z, l, m, n , which will be determined by the three coordinates in the following:

$$\begin{aligned}
 Ox &= x + udt, & xy &= y+vdt, \\
 Or &= x+dx+udt+dtdx\left(\frac{du}{dx}\right), & yz &= z+wdt \\
 Os &= x+udt+dtdy\left(\frac{du}{dy}\right), & rp &= y+vdt+dtdx\left(\frac{dv}{dx}\right), \\
 Ot &= x+udt+dtdz\left(\frac{du}{dz}\right), & pl &= z+w+dtdx\left(\frac{dw}{dx}\right) \\
 & & sq &= y + dy+vdt + dtdy\left(\frac{dv}{dy}\right), \\
 & & qm &= z+wdt + dtdy\left(\frac{dw}{dy}\right) \\
 & & to &= y+vdt+dtdz\left(\frac{dv}{dz}\right), \\
 & & on &= z+dz+wdt+dtdz\left(\frac{dw}{dz}\right).
 \end{aligned}$$

Therefore the fluid matter contained in $ZLMN$ is moved thus, so that in the elapsed time increment dt the pyramid $zlmn$ shall be occupied and filled. Indeed since the pyramid $ZLMN$ is infinitely small, however irregular the motion may have been, all the points on the individual faces of the pyramid $ZLMN$ thus it will be necessary to move, so that the remaining plane faces may remain properly ordered, and thus it is agreed the face ZLM to become the face zlm , and in a like manner for the rest.

COROLLARY 1

10. Therefore even if perhaps the shape of the molecular pyramid $ZLMN$ may change, yet it will retain the shape of a triangular pyramid, from which since any molecule may be resolved into a pyramid of this kind, hence also its shape, which is induced by the motion, will be able to be deduced.

COROLLARY 2

11. Since the principal edges of the pyramid $ZLMN$ shall be $ZL = dx$, $ZM = dy$ and $ZN = dz$, which are normal to each other, the remaining will become:

$$LM = \sqrt{(dx^2+dy^2)}, \quad LN = \sqrt{(dx^2+dz^2)}, \quad \text{and} \quad MN = \sqrt{(dy^2+dz^2)}$$

$$ZN = dz$$

and the volume of this pyramid will be $= \frac{1}{6} dx dy dz$, since the area of the base ZLM shall be $= \frac{1}{2} dx dy$ and the height $ZN = dz$.

SCHOLIUM 1

12. Therefore now we will be able also to define the individual edges of the translated pyramid $zlmn$. Indeed in the first place, on account of

$$Or - Ox = dx + dt dx \left(\frac{du}{dx} \right), \quad rp - xy = dt dx \left(\frac{dv}{dx} \right), \quad pl - yz = dt dx \left(\frac{dw}{dx} \right)$$

there will become $dx + dt dx \left(\frac{du}{dx} \right)$

$$zl = \sqrt{\left(dx^2 + 2 dt dx^2 \left(\frac{du}{dx} \right) \right)} = dx + dt dx \left(\frac{du}{dx} \right),$$

since the parts after the root sign, where the differentials may rise to the fourth order, will be allowed to be rejected ; in a similar manner there will become :

$$zm = dy + dt dy \left(\frac{dv}{dy} \right) \quad \text{and} \quad zn = dz + dt dz \left(\frac{dw}{dz} \right),$$

then for the side lm , on account of :

$$Or - Os = dx + dt dx \left(\frac{du}{dx} \right) - dt dy \left(\frac{du}{dy} \right)$$

$$sq - rp = dy - dt dx \left(\frac{dv}{dx} \right) + dt dy \left(\frac{dv}{dy} \right)$$

$$qm - pl = -dt dx \left(\frac{dw}{dx} \right) + dt dy \left(\frac{dw}{dy} \right)$$

there will become

$$lm = \sqrt{\left(dx^2 + dy^2 + 2 dt dx^2 \left(\frac{du}{dx} \right) - 2 dt dx dy \left(\frac{du}{dx} \right) - 2 dt dx dy \left(\frac{dv}{dx} \right) + 2 dt dy^2 \left(\frac{dv}{dy} \right) \right)}$$

or

$$lm = \sqrt{\left(dx^2 + dy^2 \right)} + \frac{dt dx^2 \left(\frac{du}{dx} \right) - dt dx dy \left(\frac{du}{dy} \right) - dt dx dy \left(\frac{dv}{dx} \right) + dt dy^2 \left(\frac{dv}{dy} \right)}{\sqrt{\left(dx^2 + dy^2 \right)}}.$$

Hence moreover the angle lzm is defined more conveniently, since indeed there shall be

$$\cos lzm = \frac{zl^2 + zm^2 - lm^2}{2zl \cdot zm},$$

there is found:

$$\cos lzm = \frac{2 dt dx dy \left(\left(\frac{du}{dy} \right) + \left(\frac{dv}{dx} \right) \right)}{2 dx dy} = dt \left(\frac{du}{dy} \right) + dt \left(\frac{dv}{dx} \right),$$

therefore which angle disagrees from being right by an infinitely small amount, moreover there is found in a similar manner

$$\cos lzn = dt \left(\frac{du}{dz} \right) + dt \left(\frac{dw}{dx} \right) \quad \text{and} \quad \cos mzn = dt \left(\frac{dv}{dz} \right) + dt \left(\frac{dw}{dy} \right),$$

from which it is apparent the sines of the angles approach so very close to the sine of the whole angle, so that the difference from the formula is expressed by a differential formula of the second order.

SCHOLIUM 2

13. If the question shall be concerned with the motion of solid bodies, of which the elements have been prepared thus, so that no change in its quantity nor in its shape may be permitted, the pyramid $zlmn$ must become entirely similar and equal to the pyramid $ZLMN$, from which the equality of the principal sides will supply these equations

$$\left(\frac{du}{dx}\right) = 0, \quad \left(\frac{dv}{dy}\right) = 0, \quad \left(\frac{dw}{dz}\right) = 0,$$

and truly the equality of the remaining sides these equations :

$$\left(\frac{du}{dy}\right) + \left(\frac{dv}{dx}\right) = 0, \quad \left(\frac{du}{dz}\right) + \left(\frac{dw}{dx}\right) = 0, \quad \left(\frac{dv}{dz}\right) + \left(\frac{dw}{dy}\right) = 0.$$

On account of which for solid bodies, these three speeds u , v , w of each point, necessarily must be functions of the four variables x , y , z and t , so that these six conditions shall be required. Indeed from the first it follows that the speed u cannot depend on x , nor v on y , and neither w on z . Then since there shall be $\left(\frac{du}{dy}\right) = -\left(\frac{dv}{dx}\right)$, hence it follows the formula $udx - vdy$ must be integrable, if indeed only x and y may be observed as variables, then truly in the same manner if will be necessary that these differential formulas $udx - wdz$ and $vdy - wdz$ be integrable, from which conditions the motion of solid bodies is found to be determined in the same manner, where this is accustomed to be determined from other principles. Moreover from this case it is understood also for fluids these three speeds must be defined by certain conditions; if indeed the fluid shall be of this kind, so that its density allows no change, then it is entirely necessary, that the volume of the pyramid $zlmn$ shall be equal to the volume of the pyramid $ZLMN$, and if a density variation may be allowed, from this variation the volume of the pyramid $zlmn$ may be determined, moreover in turn from this volume the variation of the density will be able to be deduced, from which the following problem arises.

PROBLEM 19

14. *With the three velocities given u , v , w , by which the individual elements of the fluid are moved, to find the variation of the density which the individual elements may take, while they are advanced in an infinitely small time dt .*

SOLUTION

As before, the element of the fluid $ZLMN$ is considered (Fig. 23), the density of this figure in this case $= q$: with the three coordinates in place $OX = x$, $XY = y$ and $YZ = z$, therefore if the volume of this pyramid $= \frac{1}{6} dx dy dz$, the mass of its element will be $= \frac{1}{6} q dx dy dz$, which also always remains the same in the motion, in whatever way meanwhile the volume may be increased or diminished. But on account of the motion, which we may attribute to this element, in the increment of the time dt it will move to $zlmn$, likewise the shape of this pyramid, and we seen its principal sides to be:

$$zl = dx + dt dx \left(\frac{du}{dx} \right), \quad zm = dy + dt dy \left(\frac{dv}{dy} \right), \quad zn = dz + dt dz \left(\frac{dw}{dz} \right),$$

moreover the angle at z to be prepared thus, so that there shall become:

$$\cos lzm = dt \left(\frac{du}{dy} \right) + dt \left(\frac{dv}{dx} \right), \quad \cos lzn = dt \left(\frac{du}{dz} \right) + dt \left(\frac{dw}{dx} \right), \quad \cos mzn = dt \left(\frac{dv}{dz} \right) + dt \left(\frac{dw}{dy} \right),$$

from which the volume of this pyramid will be required to be defined. So that we may put for the sake of brevity :

$$\cos lzm = v, \quad \cos lzn = \mu \quad \text{et} \quad \cos mzn = \lambda,$$

the volume of this pyramid thus is found from geometry, the expression

$$= \frac{1}{6} zl \cdot zm \cdot zn \sqrt{(1 - \lambda\lambda - \mu\mu - \nu\nu + 2\lambda\mu\nu)}.$$

Truly since λ , μ , ν are differentials of the first order, the squares of these rise to the second order, from which without error this volume may be put in place $= \frac{1}{6} zl \cdot zm \cdot zn$ and thus it will become

$$= \frac{1}{6} dx dy dz \left(1 + dt \left(\frac{du}{dx} \right) \right) \left(1 + dt \left(\frac{dv}{dy} \right) \right) \left(1 + dt \left(\frac{dw}{dz} \right) \right)$$

and from the expansion made and with the higher differentials rejected, the volume of the pyramid $zlmn$ is produced

$$= \frac{1}{6} dx dy dz \left(1 + dt \left(\frac{du}{dx} \right) + dt \left(\frac{dv}{dy} \right) + dt \left(\frac{dw}{dz} \right) \right);$$

now we may put in place the density of this pyramid $= q'$, which since it must produce the mass of the pyramid $ZLMN$ on being multiplied by its volume, we will have this equation on dividing each side by $\frac{1}{6} dx dy dz$:

$$q = q' + q' dt \left(\left(\frac{du}{dx} \right) + \left(\frac{dv}{dy} \right) + \left(\frac{dw}{dz} \right) \right).$$

Therefore the increment of the density is expressed thus $q' - q$, so that there shall become:

$$\frac{q' - q}{q' dt} = \frac{q' - q}{q dt} = -\left(\frac{du}{dx}\right) - \left(\frac{dv}{dy}\right) - \left(\frac{dw}{dz}\right).$$

COROLLARY 1

15. Therefore if the individual elements of the fluid experience no change in density in their enduring motion, the three speed u , v and w must be functions of this kind of x , y , z and t themselves, so that there shall become

$$\left(\frac{du}{dx}\right) + \left(\frac{dv}{dy}\right) + \left(\frac{dw}{dz}\right) = 0.$$

COROLLARY 2

16. Therefore in turn also, as often as there were

$$\left(\frac{du}{dx}\right) + \left(\frac{dv}{dy}\right) + \left(\frac{dw}{dz}\right) = 0,$$

the density of the fluid is not changed by the motion of the elements. Therefore this case happens among all the enumerable cases, if neither u may depend on x , neither v on y , nor w on z .

COROLLARY 3

17. But as often as the density of the particles is changed in the motion of the fluid, its value is known from the value of the formula $\left(\frac{du}{dx}\right) + \left(\frac{dv}{dy}\right) + \left(\frac{dw}{dz}\right)$, which where it were positive, the density decreases, but where it were negative, there the density will increase.

SCHOLION

18. Here the method used for finding the volume of the pyramid $zlmn$ is much neater and easier than that, which I used at one time in Vol. XI. Mem. Acad. Reg. Boruss. [E226] : where by many roundabout ways at last the same formula for the volume was elicited, while I have reduced its discovery here to triangular prisms. Moreover a compilation thence here has arisen, because the three angles lzm , lzn , mzn differ by an infinitely small amount from a right angle and the difference thus is expressed by the square of a differential, which unless it were convenient in use, the other method would have been preferred. Clearly since the pyramid $zlmn$ is equal to the sum of these three prisms:

$ypozln+yqozmn + poqlmn$, with the fourth $ypqzlm$ taken away, that will become

$$= \frac{1}{3} \Delta ypo (yz+pl + on) + \frac{1}{3} \Delta yqo (yz+qm+on) + \frac{1}{3} \Delta poq (pl + qm+on) \\ - \frac{1}{3} \Delta ypq (yz + pl + qm),$$

which is reduced to this form

$$\frac{1}{3} (\Delta ypo + \Delta yqo + \Delta poq) (yz+pl + qm+on) \\ - \frac{1}{3} \Delta ypo \cdot qm - \frac{1}{3} \Delta yqo \cdot pl - \frac{1}{3} \Delta poq \cdot yz \\ - \frac{1}{3} \Delta ypq (yz+pl+qm+on) + \frac{1}{3} \Delta ypq \cdot on,$$

from which on account of $\Delta ypq = \Delta ypo + \Delta yqo + \Delta poq$, becomes the pyramid

$$zlmn = \frac{1}{3} on \cdot \Delta ypq - \frac{1}{3} qm \cdot \Delta ypo - \frac{1}{3} pl \cdot \Delta yqo - \frac{1}{3} yz \cdot \Delta poq.$$

Now again these triangles are represented thus:

$$\Delta ypq = \frac{1}{2} xs(xy + sq) + \frac{1}{2} sr(rp + sq) - \frac{1}{2} xr(xy + rp) \\ = \frac{1}{2} (xs + rs) (xy + rp + sq) - \frac{1}{2} xs \cdot rp - \frac{1}{2} sr \cdot xy - \frac{1}{2} xr(xy + rp + sq) + \frac{1}{2} xr \cdot sq$$

and thus

$$\Delta ypq = \frac{1}{2} xr \cdot sq - \frac{1}{2} xs \cdot rp - \frac{1}{2} sr \cdot xy$$

and in a similar manner

$$\Delta ypo = \frac{1}{2} xr \cdot to - \frac{1}{2} xt \cdot rp - \frac{1}{2} tr \cdot xy$$

$$\Delta yqo = \frac{1}{2} xt \cdot sq - \frac{1}{2} xs \cdot to - \frac{1}{2} st \cdot xy$$

$$\Delta poq = \frac{1}{2} rt \cdot sq - \frac{1}{2} st \cdot rp - \frac{1}{2} sr \cdot to,$$

and from which at last there is deduced :

$$6zlmn = on \cdot xr \cdot sq - on \cdot xs \cdot rp - on \cdot sr \cdot xy \\ - qm \cdot xr \cdot to + qm \cdot xt \cdot rp + qm \cdot tr \cdot xy \\ - pl \cdot xt \cdot sq + pl \cdot xs \cdot to + pl \cdot st \cdot xy \\ - yz \cdot rt \cdot sq + yz \cdot st \cdot rp + yz \cdot sr \cdot to.$$

Now since all these lines have been defined above, hence the volume of this pyramid is expressed rationally, moreover with the product substituted this form is contracted into a succinct expression in the manner found.

19. With the three speeds given u , v and w , by which the individual elements of the fluid are moved, to find the acceleration, which some element takes in the infinitely small time dt .

SOLUTION

Now we may consider an element of the fluid passing through the point Z , with the coordinates $OX = x$, $XY = y$ and $YZ = z$ requiring to be determined (Fig. 24), so that carried with the speeds u , v and w , in the elapsed time dt it may arrive at the point z . Therefore this point is determined by these three coordinates

$$Ox = x+udt, \quad xy = y+vdt \quad \text{and} \quad yz = z+wdt .$$

With these in place it is enquired, by how much the three speeds, which the element now will have at z and which shall be u' , v' , w' , shall surpass these three speeds u , v , w , which it had at Z ? since the acceleration is required to be estimated from the increments. Now since u , v and w shall be functions of the four variables x , y , z and t , the speed sought at z in the elapsed time dt hence will be deduced, if the variables x , y , z and t may be increased by these increments udt , vdt , wdt and dt : on account of which we will deduce

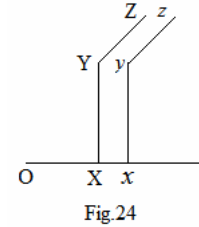

$$\begin{aligned} u' &= u+udt\left(\frac{du}{dx}\right)+vdt\left(\frac{du}{dy}\right)+wdt\left(\frac{du}{dz}\right)+dt\left(\frac{du}{dt}\right) \\ v' &= v+udt\left(\frac{dv}{dx}\right)+vdt\left(\frac{dv}{dy}\right)+wdt\left(\frac{dv}{dz}\right)+dt\left(\frac{dv}{dt}\right) \\ w' &= w+udt\left(\frac{dw}{dx}\right)+vdt\left(\frac{dw}{dy}\right)+wdt\left(\frac{dw}{dz}\right)+dt\left(\frac{dw}{dt}\right). \end{aligned}$$

Therefore since in the investigation of the motion the increment of the speed divided by the increment of the time gives the acceleration, the three accelerations sought thus will be had:

$$\begin{aligned} \frac{u'-u}{dt} &= u\left(\frac{du}{dx}\right)+v\left(\frac{du}{dy}\right)+w\left(\frac{du}{dz}\right)+\left(\frac{du}{dt}\right) \\ \frac{v'-v}{dt} &= u\left(\frac{dv}{dx}\right)+v\left(\frac{dv}{dy}\right)+w\left(\frac{dv}{dz}\right)+\left(\frac{dv}{dt}\right) \\ \frac{w'-w}{dt} &= u\left(\frac{dw}{dx}\right)+v\left(\frac{dw}{dy}\right)+w\left(\frac{dw}{dz}\right)+\left(\frac{dw}{dt}\right). \end{aligned}$$

COROLLARY 1

20. Therefore these same accelerations must result from the forces, by which the same element of fluid is disturbed, where indeed there is a need, so that the forces acting may be resolved along the same three directions.

COROLLARY 2

21. Therefore the increments of the individual speeds will depend also on the two remaining speeds ; nor here will it be allowed to make use of the common rules of mechanics, by which the acceleration of the speed u is accustomed to be expressed by $\frac{du}{dt}$.

SCHOLIUM

22. The account from the preceding is clear enough, where we have established the significance of the speeds u, v, w , as here we are forced to withdraw from that same common rule. For these speeds have not been prepared, so that they may refer always to the same element of fluid, just as is accustomed to happen in the motion of solids, but here these are referred rather to the same point of the interval, thus so that with the coordinates x, y, z , remaining, if only the time t may be put established to be variable, these shall provide the motion of its element, which in the time elapsed dt will proceed to the point Z . Whereby since here the accelerations of the same element, which now is found in Z , truly after the time increment dt is found in z , these functions will be desired u, v and w , not only through the increment of the time dt , but also must be transferred from the point Z to the point z [by the increments dx, dy , and dz], of which then the excess will be indicated over that same increment of the speed of the fluid [due to dt]. Therefore we may have fallen into a significant error, if, deceived by these simple rules, we may have expressed the accelerations by these simpler formulas $\left(\frac{du}{dt}\right), \left(\frac{dv}{dt}\right), \left(\frac{dw}{dt}\right)$, which as we see now, only constitute some part of the true acceleration.

PROBLEM 21

23. *If besides the three speeds u, v, w , which may be appropriate for the individual points of the volume through which the fluid is moved, the density q also is given at any point, to investigate the relation which exists between the speeds and the density.*

SOLUTION

We have found in problem 19, if the particles of fluid with the speeds u, v, w may be carried forwards from Z into z in the time increment dt , and its density at Z may be put $= q$, at z truly $= q'$, then to become

$$\frac{q'-q}{qdt} = -\left(\frac{du}{dx}\right) - \left(\frac{dv}{dy}\right) - \left(\frac{dw}{dz}\right).$$

But now, because the density q is observed as a function given of the four variables x, y, z and t and now indeed may indicate the density of the particles moving through the point Z , from that the density q' may be deduced, if it may be transferred in the time increment dt to the point z , and thus these increments udt, vdt, wdt and dt are required to be attributed to

the four variables x, y, z and t . On account of which it is appropriate this density q' of the same particles translated from Z to z will be expressed thus :

$$q' = q + udt \left(\frac{dq}{dx} \right) + vdt \left(\frac{dq}{dy} \right) + wdt \left(\frac{dq}{dz} \right) + dt \left(\frac{dq}{dt} \right),$$

from which there becomes:

$$\frac{q' - q}{dt} = u \left(\frac{dq}{dx} \right) + v \left(\frac{dq}{dy} \right) + w \left(\frac{dq}{dz} \right) + \left(\frac{dq}{dt} \right),$$

which value if it may be substituted into the above equation, this equation will contain the relation sought between the speeds and the density

$$q \left(\frac{du}{dx} \right) + q \left(\frac{dv}{dy} \right) + q \left(\frac{dw}{dz} \right) + u \left(\frac{dq}{dx} \right) + v \left(\frac{dq}{dy} \right) + w \left(\frac{dq}{dz} \right) + \left(\frac{dq}{dt} \right) = 0,$$

which, since there shall be $q \left(\frac{du}{dx} \right) + u \left(\frac{dq}{dx} \right) = \left(\frac{d \cdot qu}{dx} \right)$, is contracted into this:

$$\left(\frac{dq}{dt} \right) + \left(\frac{d \cdot qu}{dx} \right) + \left(\frac{d \cdot qv}{dy} \right) + \left(\frac{d \cdot qw}{dz} \right) = 0;$$

evidently here in the differentiation of qu only x , of qv only y , and of qw only z , themselves must be treated as variable.

COROLLARY 1

23[a]. Therefore if u, v and w were functions of the four given variables x, y, z and t , the equation found will indicate the nature of the function q ; but in what manner it must thence be defined may not at all be apparent.

COROLLARY 2

24. But if the density q may be given by the two speeds u and v , in as much as $\left(\frac{dq}{dt} \right) + \left(\frac{d \cdot qu}{dx} \right) + \left(\frac{d \cdot qv}{dy} \right)$ will be a known determined function of x, y, z and t , with which put $= Q$ there will become $\left(\frac{d \cdot qw}{dz} \right) + Q = 0$. Only the quantity z may be observed to be variable, and on integration there will be produced $qw + \int Q dz = \text{Const.}$, therefore $w = \frac{\text{Const.} - \int Q dz}{q}$.

SCHOLIUM 1

25. Since the resolution of the equation found :

$$\left(\frac{dq}{dt} \right) + \left(\frac{d \cdot qu}{dx} \right) + \left(\frac{d \cdot qv}{dy} \right) + \left(\frac{d \cdot qw}{dz} \right) = 0;$$

shall be of the greatest concern, on observing first for this to be satisfied, if there shall be

$$q = \Gamma : (x, y, z), \quad qu = \Delta : (t, y, z), \quad qv = \Sigma : (t, x, z), \quad qw = \Pi : (t, x, y),$$

then indeed the individual terms vanish separately, which now is the solution most widely apparent, since four arbitrary functions of three variables may be obtained. But at this stage a solution can be shown more generally with the aid of a function of all four variables x, y, z and t ; indeed if T were a function of this kind and assumed for argument's sake on differentiation, it may become:

$$dT = Fdx + Gdy + Hdz + Idt,$$

since now we know from the nature of differentiation to be:

$$\begin{aligned} \left(\frac{dF}{dt}\right) - \left(\frac{dI}{dx}\right) &= 0, \quad \left(\frac{dG}{dt}\right) - \left(\frac{dI}{dy}\right) = 0, \quad \left(\frac{dH}{dt}\right) - \left(\frac{dI}{dz}\right) = 0, \\ \left(\frac{dF}{dy}\right) - \left(\frac{dG}{dx}\right) &= 0, \quad \left(\frac{dF}{dz}\right) - \left(\frac{dH}{dx}\right) = 0, \quad \left(\frac{dG}{dz}\right) - \left(\frac{dH}{dy}\right) = 0, \end{aligned}$$

with the six constants being introduced $\alpha, \beta, \gamma, \delta, \varepsilon, \zeta$ the following values also must be taken to be satisfied :

$$\begin{aligned} q &= \alpha F + \beta G + \gamma H + \Gamma : (x, y, z) \\ qu &= -\alpha I - \delta G - \varepsilon H + \Delta : (t, y, z) \\ qv &= -\beta I + \varepsilon F - \zeta H + \Sigma : (t, x, y) \\ qw &= -\gamma I + \varepsilon F + \zeta G + H : (t, x, y) \end{aligned}$$

nor yet can it be allowed thus to observe this solution to be general, so that all possible cases may be contained within it.

SCHOLIUM 2

26. Thus if the fluid shall be homogenous, so that its density shall be the same always and everywhere, the relation between the three speeds u, v and w thus may be determined, so that there may become :

$$\left(\frac{du}{dx}\right) + \left(\frac{dv}{dy}\right) + \left(\frac{dw}{dz}\right) = 0.$$

to which also these values at once are satisfied:

$$u = \Delta : (t, y, z), \quad v = \Sigma : (t, x, z), \quad w = \Pi : (t, x, y).$$

Thence truly also the more general introduced by the function T , so that there shall be

$$dT = Fdx + Gdy + Hdz + Idt,$$

will become

$$u = -\delta G - \varepsilon H + \Delta : (t, y, z)$$

$$v = +\delta F - \zeta H + \Sigma : (t, x, z)$$

$$w = +\varepsilon F + \zeta G + \Pi : (t, x, y)$$

clearly in the above solution by putting $\alpha = 0$, $\beta = 0$, $\gamma = 0$. But here I observe there is no need, that the quantities δ , ε , and ζ shall be constants, but also able to be taken as variables, then there shall be

$$\left(\frac{d\delta}{dx}\right) - \left(\frac{d\zeta}{dz}\right) = 0, \quad \left(\frac{d\delta}{dy}\right) + \left(\frac{d\varepsilon}{dz}\right) = 0 \quad \text{et} \quad \left(\frac{d\varepsilon}{dx}\right) + \left(\frac{d\zeta}{dy}\right) = 0,$$

that is, while this formula $\zeta dx - \varepsilon dy + \delta dz$ shall be integrable. Hence besides the arbitrary function T to this another V will be allowed to be introduced, so that there shall become

$$dV = Kdx + Ldy + Mdz + Ndt,$$

and these more general values will be satisfied:

$$u = HL - GM + \Delta : (t, y, z)$$

$$v = FM - HK + \Sigma : (t, x, z)$$

$$w = GK - FL + \Pi : (t, x, y).$$

SCHOLIUM 3

27. In the same manner also in general for the variable density q a more universal solution is allowed to be rendered, with two arbitrary functions T and V of the four variables x , y , z and t being introduced. For with the differentials of these put in place:

$$dT = Fdx + Gdy + Hdz + Idt$$

and

$$dV = Kdx + Ldy + Mdz + Ndt$$

the following values of the required conditions will be satisfied:

$$q = (G+H)K + (H-F)L - (F+G)M + \Gamma : (x, y, z)$$

$$qu = (H+I)L + (I-G)M - (G+H)N + \Delta : (t, y, z)$$

$$qv = (I+F)M + (F-H)N - (H+I)K + \Xi : (t, x, z)$$

$$qw = (F+G)N + (G-I)K - (I+F)L + \Pi : (t, x, y) .$$

Then truly also two or more forms of this kind in turn may be joined together, but in this manner a more general solution cannot be considered; because, if another function taken for T such as T' may be joined with V and the values thence arising may be added to these respectively, the same solution is produced, as if at once the function $T + T'$ were accepted for T , because the same is required to be understood with regard to the other V , because they are allowed to interchange.

CHAPTER II

PRINCIPLES OF FLUID MOTION

WITH FORCES OF ANY KIND ACTING

PROBLEM 22

28. *If a fluid may be acted on by forces of any kind and the pressure at individual points may be considered as known, to find the accelerating forces, by which the individual elements are set in motion are impelled to move.*

SOLUTION

With the orthogonal coordinates put in place (Fig. 25) for the point Z : $OX = x$, $XY = y$, $YZ = z$, the figure $ZLMNzlmn$ of a rectangular parallelepiped may be attributed to the fluid element now turning around Z , contained by the differentials of the coordinates $ZL = dx$, $ZM = dy$ et $Zz = dz$, the volume of which therefore will be $= dx dy dz$, and if q may denote the density at Z , its mass will become $= q dx dy dz$. Now at

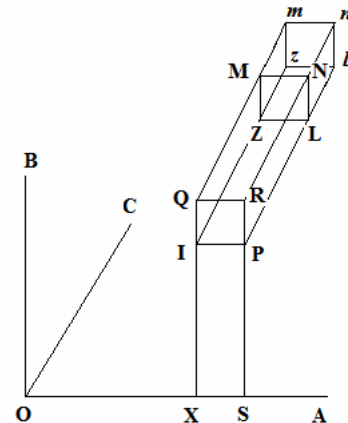

Fig. 25

first we will consider forces similar to gravity acting at the point Z , which since it may always be allowed to be resolved along the axes OA , OB , OC , there shall be these forces accelerating along OA or $ZL = P$, along OB or $ZM = Q$, and along OC or $Zz = R$, from which therefore an element of the fluid will be induced to accelerate along these same directions, to which indeed it was not necessary to attribute as certain figure to the element. Truly this figure is most useful for eliciting the accelerative forces arising from the pressure. Therefore for this time the height of the pressure at Z must become $= p$, which must be considered as a function of the four variables x , y , z and

t : from the nature of which the pressures will be able to be defined at the individual angles of the parallelepiped, as follows:

At the point	pressure is	At the point	pressure is
Z	p	z	$p+dz\left(\frac{dp}{dz}\right)$
L	$p+dx\left(\frac{dp}{dx}\right)$	l	$p+dx\left(\frac{dp}{dx}\right)+dz\left(\frac{dp}{dz}\right)$
M	$p+dy\left(\frac{dp}{dy}\right)$	m	$p+dy\left(\frac{dp}{dy}\right)+dz\left(\frac{dp}{dz}\right)$
N	$p+dx\left(\frac{dp}{dx}\right)+dy\left(\frac{dp}{dy}\right)$	n	$p+dx\left(\frac{dp}{dx}\right)+dy\left(\frac{dp}{dy}\right)+dz\left(\frac{dp}{dz}\right),$

which pressures act normally to the individual faces. We will consider the two opposite faces $ZMzm$ and $LNln$ and it is evident the pressures, which the face $LNln$ sustains at the individual points, to surpass the pressures of the face $ZMzm$ at the same opposite points by the element of pressure $dx\left(\frac{dp}{dx}\right)$, which excess alone enters into the computation. Therefore

the face $LNln$ must sustain the pressure of the height $dx\left(\frac{dp}{dx}\right)$; from which, since the area of this face shall be $=dydz$, the total pressure is equal to the weight of the volume

$dx dy dz\left(\frac{dp}{dx}\right)$, if indeed it may be considered to be filled with homogeneous matter, of

which the density $=1$: and the direction of this force, since it is normal on the face, will be parallel to the AO . Whereby our parallelepiped, of which the mass $=q dx dy dz$, will be

pushed along the direction AO by a motive force $= dx dy dz\left(\frac{dp}{dx}\right)$, which therefore divided

by the mass provides the strength of the acceleration $=\frac{1}{q}\left(\frac{dp}{dx}\right)$; by a similar account the

strength of the acceleration, by which our parallelepiped is pushed along the direction BO , $=\frac{1}{q}\left(\frac{dp}{dy}\right)$, and along the direction CO , $=\frac{1}{q}\left(\frac{dp}{dz}\right)$. Therefore since these forces are opposite

to these, by which we assume the fluid to be disturbed, the element of the fluid moving along at Z will sustain the three accelerating forces :

$$\text{along the direction } OA = P - \frac{1}{q}\left(\frac{dp}{dx}\right)$$

$$\text{along the direction } OB = Q - \frac{1}{q}\left(\frac{dp}{dy}\right)$$

$$\text{along the direction } OC = R - \frac{1}{q}\left(\frac{dp}{dz}\right).$$

In which certainly all the forces are understood which are pressing on the elements of the fluid. Indeed even if the fluid may be thrust on with the help of a pestle anywhere, hence another force is not acting on the elements, except by the pressure p , of which here we have now given an account.

COROLLARY 1

29. Therefore whatever were the exposition of the fluid forces acting, only if the pressure may be considered as known in each of its elements, hence it will be easy to designate the accelerating forces, which the individual elements of the fluid sustain.

COROLLARY 2

30. But the height indicating the pressure p thus will enter into the calculation, in as far as it is a function of the three coordinates x , y and z : if indeed in this determination of the forces the time t is assumed constant.

COROLLARY 3

30. With the accelerative forces arising from the pressure, also the density of the element of fluid q is deduced in the calculation, no account of which is given in the computation of the forces acting P , Q , R , because these forces accelerate both denser as well as rarer elements.

SCHOLIUM 1

31. Because we have seen the face $LNln$ to sustain the same pressure $dx\left(\frac{dp}{dx}\right)$ at the individual points, the mean direction of all of these forces will pass through the centre of inertial of the parallelepiped, therefore as if its infinitely small mass can be regarded as homogeneous. Just as also it shall be required to be understood with the two remaining pressures, and the forces P , Q , R of the weight likewise are themselves to be considered as passing through the applied centre of inertia, from these forces taken together no motion of gyration is impressed on the parallelepiped, yet meanwhile, it can happen, since on account of the fluidity its shape is changeable, so that in the motion its dimensions may be varied, just as its volume also, unless the density were constant, in which case it is not allowed to be changed. Nor yet hence is all the rotational motion completely excluded: for so far only all the pressures $dx\left(\frac{dp}{dx}\right)$, which the faces $LNln$ sustain, are equal, as far as here we have ignored variations of the second order, indeed certainly from which finally a rotation of the parallelepiped can arise. From that it will be allowed to deduce here, where above we have defined the translation of the element of the pyramid $ZLMN$ (Fig. 23) : because with the infinitely small time dt in place the element $zlmn$ may be brought forwards, a certain change has been made both in the size as well as in the position of the sides, which also can arise in a finite time. Truly here whatever the motion shall be, its nature will be determined by the principles requiring to be established here, nor is any other worthy circumstance allowed to be passed over, by which the motion may be affected.

SCHOLIUM 2

32. Likewise it is wonderful to be seen, what shape we may attribute here to the fluid element of the rectangular parallelepiped figure ; since if another shape were assumed, a much more difficult calculation would have become apparent, and hence it would be allowed to doubt, whether the same accelerative forces would have been elicited from the pressures ? Truly above we has shown now the effect of the pressure to depend, not on the shape of the body which sustained that, but on its volume alone: accordingly a body of water submerged shall always have a force acting upwards on account of the pressure difference acting on its volume, whatever its shape might be. Indeed it can be objected as to whether this phenomenon happens thus, because both the density of water as well as the weight is the same everywhere; while on the other hand, where the density with the forces acting will have been variable, certainly the shape of the body submerged is required to be deduced in the computation. But this doubt vanishes completely, at once as the volume sustaining the pressure is considered infinitely small, as we have done here, because in an infinitely small space all the diversity both in the density as well as in the forces acting is excluded. For this reason it is allowed to confirm now without risk, any element of the fluid considered will have a shape at Z , thence there will be no difference in the accelerative forces, which it may sustain, and thus these will pass over which we have elicited from the parallelepiped figure, and themselves to be considered correct and likewise to pertain for all the other shapes equally: therefore moreover I have used this shape, because it is most convenient for the calculation to be established. But also thence the account of the shapes has passed away at once from the conclusions drawn, evidently the document in no way depends on these shapes.

PROBLEM 23

33. *If a fluid of some kind may be acted on by forces, to establish the principles, from which its motion may be allowed to be determined.*

SOLUTION

We will consider the state of a fluid (Fig. 22), in which it will be in motion after some time $= t$, and with the three fixed axis in place OA, OB, OC normal to each other we may consider some particle of the fluid at the point Z , the place of which is determined by the three coordinates $OX = x, XY = y, YZ = z$ and which may be acted on by the three accelerative forces P, Q, R along the directions Zx, Zy, Zz parallel to the axes and with these coordinates. Now for the motion of the fluid requiring to be investigated initially the density $= q$ of the particles now in motion at Z , which therefore is required to be considered as a function of the four variables x, y, z and t . Then if now the pressure at Z must be due to the height $= p$, which always is required to be referred to uniform heavy matter, of which the density $= 1$; therefore also p will be a function of the four variables x, y, z and t . Now in the third place by whatever motion the particle may be carried around at Z , this may be resolved along these same three directions Zx, Zy, Zz , and the speed along

$Zx = u$, $Zy = v$ and $Zz = w$, which speeds we may express by the distances traversed in one second, while the time t may be expressed in seconds. Now with these in place we see this relation to be determined between these speeds and the density q , so that there shall be:

$$\left(\frac{dq}{dt}\right) + \left(\frac{d \cdot qu}{dx}\right) + \left(\frac{d \cdot qv}{dy}\right) + \left(\frac{d \cdot qw}{dz}\right) = 0.$$

Thence from the preceding problem we have found the element of fluid at Z now to be pushed on by the accelerative forces :

$$\text{along } Zx = P - \frac{1}{q} \left(\frac{dp}{dx}\right), \quad \text{along } Zy = Q - \frac{1}{q} \left(\frac{dp}{dy}\right), \quad \text{along } Zz = R - \frac{1}{q} \left(\frac{dp}{dz}\right).$$

But from the same motion attributed to this element in problem 20, we have found its acceleration along the same directions expressed thus :

$$\begin{aligned} \text{along } Zx &= u \left(\frac{du}{dx}\right) + v \left(\frac{du}{dy}\right) + w \left(\frac{du}{dz}\right) + \left(\frac{du}{dt}\right) \\ \text{along } Zy &= u \left(\frac{dv}{dx}\right) + v \left(\frac{dv}{dy}\right) + w \left(\frac{dv}{dz}\right) + \left(\frac{dv}{dt}\right) \\ \text{along } Zz &= u \left(\frac{dw}{dx}\right) + v \left(\frac{dw}{dy}\right) + w \left(\frac{dw}{dz}\right) + \left(\frac{dw}{dt}\right). \end{aligned}$$

But if now we may put the height = g , through which a heavy body may fall in one second [from rest], so that the time and the speeds may be expressed along a prescribed measure, from which any acceleration of the accelerative force is required to be multiplied by $2g$, from which we come upon the three following equations:

$$\begin{aligned} 2gP - \frac{2g}{q} \left(\frac{dp}{dx}\right) &= u \left(\frac{du}{dx}\right) + v \left(\frac{du}{dy}\right) + w \left(\frac{du}{dz}\right) + \left(\frac{du}{dt}\right) \\ 2gQ - \frac{2g}{q} \left(\frac{dp}{dy}\right) &= u \left(\frac{dv}{dx}\right) + v \left(\frac{dv}{dy}\right) + w \left(\frac{dv}{dz}\right) + \left(\frac{dv}{dt}\right) \\ 2gR - \frac{2g}{q} \left(\frac{dp}{dz}\right) &= u \left(\frac{dw}{dx}\right) + v \left(\frac{dw}{dy}\right) + w \left(\frac{dw}{dz}\right) + \left(\frac{dw}{dt}\right), \end{aligned}$$

which with that taken jointly arising from the consideration of the density contains the determination of the whole motion.

[Thus initially the two formulas for the acceleration may be considered to be in proportion, and in order to evaluate the constant of proportionality a very simple situation may be taken where a weight is dropped for a time of one second through a height g ; the force acting on an element of the liquid is then compared to the force of gravity by the ratio of the distances gone, which is taken to be $2g: 1$.]

COROLLARY 1

34. Therefore the whole problem is reduced to this, so that for the quantities p, q, u, v, w functions of this kind of the four variables x, y, z and t may be found, which may satisfy these four equations, which evidently when these can be done in an infinite number of ways, the nature of the problem then demands especially.

COROLLARY 2

35. But since either the density q shall be constant, or may depend on the pressure p alone or in addition on the heat, hence a new condition arises requiring to be adjoined to the conditions found, and that question therefore is more restricted.

COROLLARY 3

36. Therefore since the density q may be given from elsewhere, for the four remaining unknowns p, q, u, v, w we have gained four equations, from which it is evident here the solution given to be complete and no condition to be set aside, of which in addition an account will be required to be had.

SCHOLIUM

37. Therefore in these equations found the whole theory of the motion of fluids is thus contained, so that it may be extended not only to fluids of all kinds, but also to all the forces arising, by which the fluids may be disturbed. Truly this whole theory is set out as a new kind of calculus and thus the force extracted, since by integration the independent functions of the four variables x, y, z and t will be able to be extracted from that in turn. To some extent a calculus of this kind may be unusual and abstruse, hence it will be allowed to deduce, so that the universal integral calculus shall be considered carefully, to the extent that as well as being improved, only a function of one variable is taken for investigation and even now that part is small, which is concerned with functions of two variables, whether it is required to refer to the problem of vibrating cords involving the greatest difficulty. Therefore since here thus functions of four variables must be investigated, it is readily perceived, how great the aids to the calculation may be desired at this stage. Therefore it is required to be especially incumbent, that we may return the equations found either to be simpler or reduced to a smaller number, so that in turn the setting out of these may be undertaken more easily. And indeed the last three of these equations are required to be prepared thus, so that they may be joined together into one, but in which the strength of the individual equations is included, just as we will explain in the following problem.

PROBLEM 24

38. *If besides the forces $P, Q,$ and R acting, also the speeds of each three points u, v and w with the density q may be observed as given, the pressure p to be determined by a single equation.*

SOLUTION

The three equations , which we have elicited in the preceding problem, show in the first the value of $\left(\frac{dp}{dx}\right)$, in the second that of $\left(\frac{dp}{dy}\right)$, and in the third that of $\left(\frac{dp}{dz}\right)$ itself. Therefore, since p shall be a function of the four variables x, y, z and t , if we may consider t as constant, certainly there will be :

$$dp = dx\left(\frac{dp}{dx}\right) + dy\left(\frac{dp}{dy}\right) + dz\left(\frac{dp}{dz}\right),$$

from which we will be able to reduce the whole matter to the absolute differential dp . To this end for the sake of brevity we may establish

$$u\left(\frac{du}{dx}\right) + v\left(\frac{du}{dy}\right) + w\left(\frac{du}{dz}\right) + \left(\frac{du}{dt}\right) = U$$

$$u\left(\frac{dv}{dx}\right) + v\left(\frac{dv}{dy}\right) + w\left(\frac{dv}{dz}\right) + \left(\frac{dv}{dt}\right) = V$$

$$u\left(\frac{dw}{dx}\right) + v\left(\frac{dw}{dy}\right) + w\left(\frac{dw}{dz}\right) + \left(\frac{dw}{dt}\right) = W$$

so that the three equations may become as found before:

$$\frac{2g}{q}\left(\frac{dp}{dx}\right) = 2gP - U, \quad \frac{2g}{q}\left(\frac{dp}{dy}\right) = 2gQ - V, \quad \frac{2g}{q}\left(\frac{dp}{dz}\right) = 2gR - W,$$

of which if the first may be multiplied by dx , the second by dy and the third by dz , on account of

$$dx\left(\frac{dp}{dx}\right) + dy\left(\frac{dp}{dy}\right) + dz\left(\frac{dp}{dz}\right) = dp,$$

with dp denoting the differential of the pressure p while the time t is considered constant, by addition we will obtain this equation :

$$\frac{2gdp}{q} = 2g(Pdx + Qdy + Rdz) - Udx - Vdy - Wdz,$$

from which now it will be required to find the pressure p by integration. But it will be required to be observed only this equation to be accessible equally widely, and the three preceding ones taken together, and these individual ones thus to be included together, so that without the omission of any may be able to be substituted in place of the three other equations. So that indeed if in general there were

$$dp = Ldx + Mdy + Ndz,$$

this single equation will be included with these three equations

$$\left(\frac{dp}{dx}\right) = L, \quad \left(\frac{dp}{dy}\right) = M \quad \text{et} \quad \left(\frac{dp}{dz}\right) = N,$$

nor will more be able to be determined from these three equations, than that single one.

COROLLARY 1

39. Now therefore the universal theory of the motion of fluids will be contained in these two equations :

$$\text{I.} \quad \left(\frac{dq}{dt}\right) + \left(\frac{d \cdot qu}{dx}\right) + \left(\frac{d \cdot qv}{dy}\right) + \left(\frac{d \cdot qw}{dz}\right) = 0,$$

$$\text{II.} \quad \frac{2gdp}{q} = 2g(Pdx + Qdy + Rdz) - Udx - Vdy - Wdz,$$

but to which in addition the relation between the density q and the pressure p must be added, as the nature of the fluid demands.

COROLLARY 2

40. In the latter of these equations the time t is assumed to be constant, from which by an absolute integration in the value of p in place of the constant some arbitrary function of the time t may be introduced : in whatever manner the nature of the circumstances may demand, just as any moment of the internal pressures p can be changed as it pleases by external forces.

COROLLARY 3

41. If the quantities U , V and W in the latter equation may be considered as functions given of x , y and z , thus it will be required to compare these, so that the equation may be allowed to be integrated ; for unless this may eventuate, clearly motion of this kind is going to become impossible to be had.

SCHOLIUM 1

42. Now we have observed the accelerative forces P , Q , R more often which indeed are found in the world, always to be prepared thus, so that the formula of the differentials $Pdx + Qdy + Rdz$ may be allowed to be integrated, whose integral is that, which may be permitted to be called the magnitude of the action. So that therefore if this action may be indicated by the letter S , the following equation will adopt this form:

$$\frac{2gdp}{q} = 2gdS - Udx - Vdy - Wdz.$$

Whereby if the form $Udx + Vdy + Wdz$ may be allowed to be integrated and its integral may be called T , so that there shall become

$$\frac{2gdp}{q} = 2gdS - dT,$$

where now the conditions of integrability clearly are satisfied well enough as it were, if q shall be either a constant quantity or depending on the pressure p only, the integral shall become :

$$2g \int \frac{dp}{q} = 2gS - T - \Gamma : t,$$

then truly if q were a quantity depending on p and $2gS - T$ in some manner, an equation is required to be obtained equally for each possibility, to the extent that only the two variables p and $2gS - T$ are involved ; then truly both p as well as q separately will be equated to certain functions of the quantity $2gS - T$, in which indeed t can be introduced in the manner of some constant. And from this case it is understood readily for that, so that our second equation may be allowed to be integrated, to be required absolutely, so that with the aid of some substitution it may be allowed to be changed into a form involving only two variables. Indeed whatever equations are possible between three or more variables, so that, with the cases used it may arise that certain criteria are accustomed to be treated in analysis, these criteria return always to this, so that with the aid of certain substitutions these equations may be able to be reduced to only two variables; just as we have seen to happen in the case set out before.

SCHOLIUM 2

43. But for this hypothesis, where we have assumed the integrable formula $Udx + Vdy + Wdz$, we bring significant restrictions to our general formula. Indeed it may be observed a threefold determination to be introduced for this restriction, since with that it is required that there shall be

$$\left(\frac{dU}{dy}\right) = \left(\frac{dV}{dx}\right), \quad \left(\frac{dU}{dz}\right) = \left(\frac{dW}{dx}\right) \quad \text{and} \quad \left(\frac{dV}{dz}\right) = \left(\frac{dW}{dy}\right),$$

but it is required to be observed, while with two of these three formulas were satisfied, there the third itself also would be satisfied. Indeed we may put the relation between U , V and W thus to be limited, so that the first two formulas may be implemented, and from these for further to be elicited by differentiation:

$$\left(\frac{ddU}{dydz}\right) = \left(\frac{ddV}{dx dz}\right) = \left(\frac{ddW}{dx dy}\right).$$

Therefore since there shall be $\left(\frac{ddV}{dx dz}\right) = \left(\frac{ddW}{dx dy}\right)$, this equation certainly now includes that third formula $\left(\frac{dV}{dz}\right) = \left(\frac{dW}{dy}\right)$ within itself. From which perhaps we restrict our general equation to a twofold determination. Then truly also these quantities U , V and W require careful thought on account of the first general equation depending also on the density q , thus so that it will be no longer free for us to form conditions of this kind, if indeed the quantity q also itself enters into another equation. Yet meanwhile this is certain, whatever values it may be allowed work out for the quantities p , q , u , v , w , but which it may satisfy each equation, from these it will be possible for some motion to be shown, only if a fluid of this kind may exist, whose density may agree with the account of the pressure in some manner. But the first general equation, in which neither the forces P , Q , R nor the pressure may be present, will be allowed to be treated without being with respect to the other: moreover its integration thus can happen to be considered to be complete, as I have established in the following problem.

PROBLEM 25

44. To investigate the complete integration of the first equation found for the motion of fluids :

$$\left(\frac{d \cdot qu}{dx}\right) + \left(\frac{d \cdot qv}{dy}\right) + \left(\frac{d \cdot qw}{dz}\right) + \left(\frac{dq}{dt}\right) = 0.$$

SOLUTION

The question therefore is reduced to this, so that the most general equation of this kind may be resolved :

$$\left(\frac{dP}{dx}\right) + \left(\frac{dQ}{dy}\right) + \left(\frac{dR}{dz}\right) + \left(\frac{dS}{dt}\right) = 0,$$

or, so that in general for the four quantities P , Q , R , S functions of this kind of the four variables x , y , z and t may be assigned, which not only may satisfy this equation, but also entirely all solutions may be themselves included. So that we may attain this goal with greater care and certainty, by beginning from the simplest cases we will rise successively to this proposition. And indeed in the first place, if a single variable x may be had, the equation and the equation may depend on the single term $\left(\frac{dP}{dx}\right) = 0$, the complete integral is

$$P = \text{Const.}$$

Now two variables x and y may be allowed, and this equation shall be required to be integrated

$$\left(\frac{dP}{dx}\right) + \left(\frac{dQ}{dy}\right) = 0.$$

This in general will best be established by taking some arbitrary function of the two variables x and y , which shall be O , with which differentiated there may become

$dO = Kdx + Ldy$: and evidently is that equation from these functions completely integrated:

$$P = L + \Gamma : y \quad \text{and} \quad Q = -K + \Delta : x.$$

The three variables x, y, z , may be put in put in place so that this equation must be integrated

$$\left(\frac{dP}{dx}\right) + \left(\frac{dQ}{dy}\right) + \left(\frac{dR}{dz}\right) = 0$$

as we have seen above (paragraph 25) for this to be maintained as it pleases, two functions of the three variables x, y and z can be assumed, which if they were O and o , from the differentiation of these there may be produced

$$dO = Kdx + Ldy + Mdz \quad \text{and} \quad do = kdx + ldy + mdz,$$

and the general solution will be:

$$\begin{aligned} P &= Lm - Ml + \Gamma : (y, z), \\ Q &= Mk - Km + \Delta : (x, z), \quad \text{et} \\ R &= Kl - Lk + \Sigma : (x, y). \end{aligned}$$

Which solution since besides the two functions O and o assumed for argument's sake in addition three arbitrary functions of the two variables may be included, certainly is required for the complete solution to be obtained.

Hence therefore the account of the same equation requiring to be resolved is included, in which four variables may be contained:

$$\left(\frac{dP}{dx}\right) + \left(\frac{dQ}{dy}\right) + \left(\frac{dR}{dz}\right) + \left(\frac{dS}{dt}\right) = 0$$

Here evidently three functions of the four variables may be assumed for argument's sake, O, o, w , of which the differentials shall be :

$$\begin{aligned} dO &= Kdx + Ldy + Mdz + Ndt \\ do &= kdx + ldy + mdz + ndt \\ d\omega &= \chi dx + \lambda dy + \mu dz + vdt, \end{aligned}$$

and hence the functions sought P, Q, R, S may be defined thus, so that there shall be

$$\begin{aligned}
P &= +Lmv + Mn\lambda + Nl\mu - Lnv - Mlv - Nm\lambda + \Gamma : (y, z, t) \\
Q &= -Mn\chi - Nk\mu - Kmv + Mkv + Nm\chi + Kn\mu + \Delta : (x, z, t) \\
R &= +Nk\lambda + Klv + Ln\chi - Nl\chi - Kn\lambda - Lkv + \Sigma : (x, y, t) \\
S &= -Kl\mu - Lm\chi - Mk\lambda + Km\lambda + Lk\mu + Ml\chi + \Pi : (x, y, z),
\end{aligned}$$

since which values may be satisfied, and in addition following the law of the progression, three arbitrary functions of the four variables are involved, together with four functions of the three variables likewise are required to be taken by choice, without doubt are agreed to constitute the whole integration.

COROLLARY 1

45. Lest the multitude of letters may overwhelm the mind, in place of the functions O, o, w we may write the letters F, G, H , and from these differential formulas the solution of our problem thus itself will be had:

$$\begin{aligned}
qu &= \left(\frac{dF}{dy}\right)\left(\frac{dG}{dz}\right)\left(\frac{dH}{dt}\right) + \left(\frac{dF}{dz}\right)\left(\frac{dG}{dt}\right)\left(\frac{dH}{dy}\right) + \left(\frac{dF}{dt}\right)\left(\frac{dG}{dy}\right)\left(\frac{dH}{dz}\right) \\
&\quad - \left(\frac{dF}{dy}\right)\left(\frac{dG}{dt}\right)\left(\frac{dH}{dz}\right) - \left(\frac{dF}{dz}\right)\left(\frac{dG}{dy}\right)\left(\frac{dH}{dt}\right) - \left(\frac{dF}{dt}\right)\left(\frac{dG}{dz}\right)\left(\frac{dH}{dy}\right) + \Gamma : (y, z, t) \\
qv &= -\left(\frac{dF}{dz}\right)\left(\frac{dG}{dt}\right)\left(\frac{dH}{dx}\right) - \left(\frac{dF}{dt}\right)\left(\frac{dG}{dx}\right)\left(\frac{dH}{dz}\right) - \left(\frac{dF}{dx}\right)\left(\frac{dG}{dz}\right)\left(\frac{dH}{dt}\right) \\
&\quad + \left(\frac{dF}{dz}\right)\left(\frac{dG}{dx}\right)\left(\frac{dH}{dt}\right) + \left(\frac{dF}{dt}\right)\left(\frac{dG}{dz}\right)\left(\frac{dH}{dx}\right) + \left(\frac{dF}{dx}\right)\left(\frac{dG}{dt}\right)\left(\frac{dH}{dz}\right) + \Delta : (x, z, t) \\
qw &= \left(\frac{dF}{dt}\right)\left(\frac{dG}{dx}\right)\left(\frac{dH}{dy}\right) + \left(\frac{dF}{dx}\right)\left(\frac{dG}{dy}\right)\left(\frac{dH}{dt}\right) + \left(\frac{dF}{dy}\right)\left(\frac{dG}{dt}\right)\left(\frac{dH}{dx}\right) \\
&\quad - \left(\frac{dF}{dt}\right)\left(\frac{dG}{dy}\right)\left(\frac{dH}{dx}\right) - \left(\frac{dF}{dx}\right)\left(\frac{dG}{dt}\right)\left(\frac{dH}{dy}\right) - \left(\frac{dF}{dy}\right)\left(\frac{dG}{dx}\right)\left(\frac{dH}{dt}\right) + \Sigma : (x, y, t) \\
q &= -\left(\frac{dF}{dx}\right)\left(\frac{dG}{dy}\right)\left(\frac{dH}{dz}\right) - \left(\frac{dF}{dy}\right)\left(\frac{dG}{dz}\right)\left(\frac{dH}{dx}\right) - \left(\frac{dF}{dz}\right)\left(\frac{dG}{dx}\right)\left(\frac{dH}{dy}\right) \\
&\quad + \left(\frac{dF}{dx}\right)\left(\frac{dG}{dz}\right)\left(\frac{dH}{dy}\right) + \left(\frac{dF}{dy}\right)\left(\frac{dG}{dx}\right)\left(\frac{dH}{dz}\right) + \left(\frac{dF}{dz}\right)\left(\frac{dG}{dy}\right)\left(\frac{dH}{dx}\right) + \Pi : (x, y, z).
\end{aligned}$$

COROLLARY 2

46. This law can be readily observed without the multitude of terms standing in the way, where the parts for the individual values may be combined, evidently in the first expression the element dx does not appear, in the second dy is omitted, in the third dz and in the fourth dt . Then truly, if in the first in place of dy there may be written dx and with the signs changed the second arises, truly if in place of dz there may be written dx , the third arises: and thus it will be allowed to elicit as you please from any remaining given.

COROLLARY 3

47. Then truly also in any expression these three members are provided with the same signs, which have no common factors; but those which have a common factor are provided with opposite signs. Finally in different expressions which members have no common factor, these have different signs, these which have a single common factor with the same sign, and which have two common factors, again are given different signs.

SCHOLIUM 1

48. Moreover not only does any member of each expression correspond to one expression in the remaining expressions, as there are two common factors with that, which may be especially noteworthy, because the whole demonstration of this solution depends on that, that is shown in the following manner. The term $\left(\frac{dF}{dy}\right)\left(\frac{dG}{dz}\right)\left(\frac{dH}{dt}\right)$ may be taken from the form qu , for which in the rest there must be another term, so that with this it may have two common factors $\left(\frac{dF}{dy}\right)\left(\frac{dG}{dz}\right)$. But is apparent such a member can occur neither in the form qv (since here dy is excluded) nor in the form qw (since here dz is excluded) : but certainly must be found in the form q , and that singly with the opposite sign attached

$-\left(\frac{dF}{dy}\right)\left(\frac{dG}{dz}\right)\left(\frac{dH}{dx}\right)$, which likewise is required to be held by any from the other two terms.

Now with this overcome the demonstration of our solution will be had thus : only terms of this kind are required to be considered having two given common factors, which are found for this form for the common factors $\left(\frac{dF}{dy}\right)\left(\frac{dG}{dz}\right)$:

$$qu = \left(\frac{dF}{dy}\right)\left(\frac{dG}{dz}\right)\left(\frac{dH}{dt}\right) + \text{etc.}, \quad q = -\left(\frac{dF}{dy}\right)\left(\frac{dG}{dz}\right)\left(\frac{dH}{dx}\right) + \text{etc.}$$

from which, for the equation proposed required to be integrated :

$$\left(\frac{d \cdot qu}{dx}\right) + \left(\frac{d \cdot qv}{dy}\right) + \left(\frac{d \cdot qw}{dz}\right) + \left(\frac{dq}{dt}\right) = 0$$

we may elicit the single diverse factors to be differentiated:

$$\left(\frac{d \cdot qu}{dx}\right) = \left(\frac{dF}{dy}\right)\left(\frac{dG}{dz}\right)\left(\frac{ddH}{dt dx}\right) + \text{etc.}$$

$$\left(\frac{dq}{dt}\right) = -\left(\frac{dF}{dy}\right)\left(\frac{dG}{dz}\right)\left(\frac{ddH}{dt dx}\right) + \text{etc.}$$

where these two terms mutually cancel out. From which it is understood, if for qu , qv , qw and q all the expressions found may be substituted and the individual members are to be differentiated, with which agreed on the individual members may be set out in three parts, all these parts mutually cancel themselves out. Accordingly while the individual terms are differentiated, thence for the three factors in the differentials three new terms result, in which only one factor from the two remaining may be differentiated, from which, since

that concerned with the cancellation of the differentiated term $\left(\frac{dF}{dy}\right)\left(\frac{dG}{dz}\right)\left(\frac{ddH}{dtdx}\right)$ is required to be shown, the same likewise plainly is required to be judged to prevail for all.

SCHOLIUM 2

49. From the solution of the problem, while we have progressed by steps to the proposed equation, the case where the density of the fluid q is constant and the first equation this will itself be had we will be able to resolve :

$$\left(\frac{du}{dx}\right) + \left(\frac{dv}{dy}\right) + \left(\frac{dw}{dz}\right) = 0,$$

since further from that it is required to be observed, since the solution of this problem from the general one, which we have given, will not be allowed to be derived. Although here only the three variables x , y and z will be required to be considered, yet there is no reason to prevent, why we may not introduce a fourth time t into the solution given there that may be required to be considered as if constant. Therefore with the two functions F , G taken for argument's sake of the four variables x , y , z and t , from these the three speeds u , v and w will be determined thus, so that there shall become :

$$u = \left(\frac{dF}{dy}\right)\left(\frac{dG}{dz}\right) - \left(\frac{dF}{dz}\right)\left(\frac{dG}{dy}\right) + \Gamma : (y, z, t)$$

$$v = \left(\frac{dF}{dz}\right)\left(\frac{dG}{dx}\right) - \left(\frac{dF}{dx}\right)\left(\frac{dG}{dz}\right) + \Delta : (x, z, t)$$

$$w = \left(\frac{dF}{dx}\right)\left(\frac{dG}{dy}\right) - \left(\frac{dF}{dy}\right)\left(\frac{dG}{dx}\right) + \Sigma : (x, y, t),$$

where the whole state of affairs is present again there, so that again the whole moment in any term of each form may correspond to some other term in the remainder, since from that given factor a common factor may be had with the opposite sign in place. But here the whole case, where the density of the fluid is a constant quantity, deserves a mention, so that it may be set out separately with care, to which business the following chapter is the concern. Moreover to be observed here the analysis used by this method also will help similar equations to be resolved, where more than variables four may occur ; but the number of the members thus grows, so that it may become exceedingly prolix perhaps to evolve into the case of five variables.

CHAPTER III

APPLICATION OF THESE PRINCIPLES TO FLUIDS

OF THE SAME DENSITY EVERYWHERE

PROBLEM 26

50. *If the density of a fluid shall be the same everywhere and always, and that may be acted on by some forces, to determine its motion by analytical formulas.*

SOLUTION

These will refer the densities to that case, which were treated in the preceding chapter concerned with the motion of fluids of any kind, where the density was placed variable, by equating the density to be placed as a constant, which shall be b , thus so that we will have $q = b$.

Hence at once the first equation will be contained in this form:

$$\left(\frac{du}{dx}\right) + \left(\frac{dv}{dy}\right) + \left(\frac{dw}{dz}\right) = 0,$$

as with any two functions F and G taken of the variables x, y, z and t , thus we have seen to be integrated completely, so that there shall be

$$\begin{aligned} u &= \left(\frac{dF}{dy}\right)\left(\frac{dG}{dz}\right) - \left(\frac{dF}{dz}\right)\left(\frac{dG}{dy}\right) + \Gamma : (y, z, t) \\ v &= \left(\frac{dF}{dz}\right)\left(\frac{dG}{dx}\right) - \left(\frac{dF}{dx}\right)\left(\frac{dG}{dz}\right) + \Delta : (x, z, t) \\ w &= \left(\frac{dF}{dx}\right)\left(\frac{dG}{dy}\right) - \left(\frac{dF}{dy}\right)\left(\frac{dG}{dx}\right) + \Sigma : (x, y, t), \end{aligned}$$

where Γ, Δ, Σ denote functions of this kind, so that there shall become

$$\left(\frac{d\Gamma}{dx}\right) = 0, \quad \left(\frac{d\Delta}{dy}\right) = 0, \quad \text{and} \quad \left(\frac{d\Sigma}{dz}\right) = 0.$$

For the other equation we may put for the sake of brevity

$$\begin{aligned} u\left(\frac{du}{dx}\right) + v\left(\frac{dv}{dy}\right) + w\left(\frac{dw}{dz}\right) + \left(\frac{du}{dt}\right) &= U \\ u\left(\frac{dv}{dx}\right) + v\left(\frac{dv}{dy}\right) + w\left(\frac{dv}{dz}\right) + \left(\frac{dv}{dt}\right) &= V \\ u\left(\frac{dw}{dx}\right) + v\left(\frac{dw}{dy}\right) + w\left(\frac{dw}{dz}\right) + \left(\frac{dw}{dt}\right) &= W \end{aligned}$$

and this same equation will have this form:

$$\frac{2gdp}{b} = 2g(Pdx + Qdy + Rdz) - Udx - Vdy - Wdz,$$

where since the formula $Pdx + Qdy + Rdz$ always shall itself be integrable, on putting its integral = S , there will become

$$\frac{2gdp}{b} = 2gdS - Udx - Vdy - Wdz,$$

in which differential equation it will be observed the time t be assumed to be constant. Therefore since from the first equation the speeds u, v, w now will be expressed by the four variables x, y, z and t , from this the pressure p also will be shown by the same variables, while this equation were possible, which is unable to happen, unless the formula $Udx + Vdy + Wdz$ itself may be allowed to be integrated, from which condition the integration of the first equation is not very restricted by this condition. Moreover on putting this integral $= T$ there will become:

$$\frac{2gp}{b} = 2gS - T + f : t$$

in place of a constant some function of t being required to be added.

COROLLARY 1

51. Therefore with the integration from the most general of the first equations only these cases are required to be allowed, in which likewise the formula $Udx + Vdy + Wdz$ may be returned integrable: since which condition will demand two determinations, these general functions F, G and Γ, Δ, Σ require a twofold restriction.

COROLLARY 2

52. Therefore for the three speeds u, v, w functions of this kind of the four variables x, y, z and t will require to be investigated, so that in the first place

$$\left(\frac{du}{dx}\right) + \left(\frac{dv}{dy}\right) + \left(\frac{dw}{dz}\right) = 0,$$

then truly in addition it is required for these formulas to be satisfied

$$\left(\frac{dU}{dy}\right) = \left(\frac{dV}{dx}\right), \quad \left(\frac{dU}{dz}\right) = \left(\frac{dW}{dx}\right) \quad \text{and} \quad \left(\frac{dV}{dz}\right) = \left(\frac{dW}{dy}\right),$$

of which indeed two of the three latter conditions are themselves involved with the third, thus so that generally all three conditions may be had.

SCHOLIUM

53. Therefore the first integration, even if it may succeed generally, yet scarcely offers any help for solving the problem proposed, because the determination of these functions, which we have found for the three speeds u, v and w , as the formula: $Udx + Vdy + Wdz$ may avoid being integrable, since it may receive the minimum aid. And certainly it would

be imprudent in such a difficult investigation to hope for such an easy resolution, since even the determination of the motion of solid bodies may be subjected to the greatest difficulty. Indeed even if the case for these bodies presented at last is happily established, where no forces are acting, yet plainly there is no doubt, why the motion of fluids may not be much more abstruse. From which investigations thus it will be agreed to be directed, so that perhaps we may examine several particular cases, in which the motion of fluids may be allowed to be defined. And in the first place indeed that motion parallel to itself presents itself, where the fluid thence is progressing as a solid body, which therefore may be considered more accurately, and will need hardly any help to be derived from our formulas : therefore the whole matter will be illustrated very well, if we may subject the previous case to be examined, where the three speeds plainly vanish ; thus even if with all motion removed and the fluid is reduced to equilibrium, yet, since the pressure can be variable, here several things will occur requiring to be observed, which will be useful in the following.

PROBLEM 27

54. *If the three velocities u, v, w of any fluid element may vanish, moreover any forces indicated by the letters P, Q, R may act on the liquid, since the fluid is assumed to remain at rest, to define the pressure of the fluid both at single elements as well as for any time t .*

SOLUTION

It is evident at once this hypothesis $u = 0, v = 0, w = 0$ satisfies the first equation

$$\left(\frac{du}{dx}\right) + \left(\frac{dv}{dy}\right) + \left(\frac{dw}{dz}\right) = 0.$$

Then truly on account of $U = 0, V = 0, W = 0$ the other equation adopts this form :

$$\frac{dp}{b} = Pdx + Qdy + Rdz,$$

from which it is evident this hypothesis of being at rest is unable to be fulfilled, unless the forces P, Q, R may be prepared thus, so that the formula $Pdx + Qdy + Rdz$ may be integrated. Therefore if its integral shall be $= S$, so that there shall be $dp = b dS$, and since the time t is assumed constant, the complete integral will be $p = bS + \Gamma : t$ evidently with some function of the time t being required to be added on. Therefore for the same moment, the pressure through the whole mass of the fluid must depend on the quantity S , thus so that with the equilibrium in layers, through which S has the same value everywhere, the pressure shall be equal, just as has been shown in the first section on equilibrium. But now it is apparent in addition, because there it not designated, it can happen, so that at the same point Z the pressure may be varied in some manner at successive times. Because also it agrees amazingly with the nature of the question : indeed the fluid of a vessel may be considered to be included, in which it may be pressed hard by some force with the help of

a piston, and thus while no compression is apparent, without doubt it will be in equilibrium. Here truly the state of equilibrium will not be disturbed, even if the driving force of the piston may be changed continually either by some rule, or also without any rule, but hence the pressure in the fluid also will be changed continually. Whereby since our solution may include all the possible resting cases within it, the reasoning is clear, why some function of the time may enter into the expression found for p .

COROLLARY 1

55. Therefore this function of the time t in some case must be determined from the variation of the force by which the piston is impelled: which if it were arbitrary and not restricted by any rule, this function also is required to be referred to the kind of these, which I have called discontinuous : from which the necessity of functions of this kind in analysis is shown much more clearly.

COROLLARY 2

56. Therefore so that if for a given time the pressure at some point were known, for the same moment of time it will be able to assign the pressure at all the other points, clearly which will depend only on the quantity S . But neither the preceding nor the following will depend on these in any way.

SCHOLIUM

57. While here the enclosed fluid of a vessel may be considered to have some force exerted on it with the aid of the piston, this itself is understood, unless the vessel may be fixed in place, it must be able to sustain any moment from such forces, which may suffice by requiring to hold that in a state of rest; otherwise the case will not agree with the assumed hypothesis. But these equally small external forces and that, which is applied by the piston, are entered into our differential formulas, since they do not affect the motion of the particles of the fluid directly, while the individual elements are acted on only by the natural forces P , Q , R and by the pressure: truly at last on integrating these arbitrary functions are carried through by the integrals, and all these external forces and other circumstances must be adapted for all these other circumstances. Moreover the external forces are of two kinds, of which in the one case they act on the vessel as a solid body and do not affect the fluid itself, truly of the other kind, as if applied with a piston likewise they act both on the vessel itself as well as on the fluid. Truly also in addition the vessel itself will sustain the same force from the same forces P , Q , R , as if with the fluid there were put in place a single solid body to be accessible to the action of these forces ; from which it may be readily understood, with how great forces will there be a need, for the continued state of rest of the vessel, lest with the vessel, also the fluid may be disturbed from its state of rest.

PROBLEM 28

58. *If the speeds u, v, w of each point Z were constant, thus so that the individual elements may be carried along in the same direction with a uniform motion, while it may be acted on by whatever accelerative forces, to investigate the pressures of the fluid everywhere and for all times.*

SOLUTION

Therefore the mass of the whole fluid is moved likewise, just as a solid body; therefore if it may include the mass of the vessel, this vessel will be moved uniformly along with the fluid, certainly motion of this kind can be obtained, not from the opposition of the fluid forces P, Q, R acting, but while forces of this kind are applied externally to the vessel, which may be put in place in some manner with these in equilibrium. Then truly, if between these, forces may act on the fluid itself with some help from the piston, since that can be varied at will, also the pressures in the fluid will be able to be changed arbitrarily by some means, which has to be deduced from the solution declared. Now, on account of the three constant speeds, there may be put $u = \alpha, v = \beta, w = \gamma$, and indeed the first equation is satisfied at once. Then truly there shall become $U = 0, V = 0, W = 0$, from which on account of

$$Pdx + Qdy + Rdz = dS$$

there will be as before

$$dp = b dS \text{ and } p = bS + f : t.$$

Therefore by whatever means the pressure throughout the whole vessel will be given by $p = bS + C$, and thus it will depend on the action of the force S in the same manner, as in the case of being at rest, but this pressure can be varied with the time as it pleases, just as the nature of the question may demand to be used.

SCHOLIUM

59. This case will be able to be deduced from the preceding case, where the total mass of the fluid will persist at rest, following the usual principle of mechanics, so that in the motion of the body everything remains the same, if in addition the whole system of those may be considered to be carried forwards uniformly. Truly here on account of the forces P, Q, R acting, some distinction is to be agreed on; for on being at rest any element of the fluid always sustains the same forces acting, but while the mass of the fluid is progressing and the same element traverses other and still other places, certainly it can happen, so that successively it may be acted on by other and still more other forces, if indeed these forces depend on a location, as generally it is accustomed to happen. Therefore since for the same element of the fluid here the quantity S shall be variable, which in the case of being at rest will remain constant, unless there were need of a special solution. But properly it is required to be maintained, unless the forces acting may be prepared thus, so that the formula $Pdx + Qdy + Rdz$ is allowed to be integrated, while such an equally small motion can occur as well as the rest case, and also in some way the extrinsic forces may be

attempted to be adjusted. Evidently if a case of this kind were to arise, even if an initial uniform motion were direct to the fluid, this may not be able to be conserved in any way, but the stability may be disturbed continually; and thus in this case a contradiction is required to be considered to the hypothesis of a constant speed. Hence finally it is understood more clearly that all the external circumstances cannot enter into canonical equations expressing the motion of fluids, such as of the vessel, and the forces acting either on the vessel alone, or on the fluid with the aid of a piston, but finally for the integration to be performed to be necessary for arbitrary functions to be brought in for these to be accommodated, which functions also always are prepared thus, clearly so that all the external circumstances may themselves be included.

PROBLEM 29

60. *If the speeds of any point u , v , w may be expressed by functions of the time t only, to investigate, whether such a motion may be able to exist and under which conditions, while the individual particles of the fluid may be disturbed by forces of some kind, then truly to investigate the pressure through the whole mass of the fluid.*

SOLUTION

Therefore at the same instant of the time all the elements of the fluid may be carried in the same direction with an equal motion, and the change both of the speed as well as of the direction induced may be established by calculation for all the flow in equal times ; from which since the individual elements of the fluid will always maintain the same distances between themselves, the total mass may be advanced in the image of a solid body, and since it is described always by the same terms, it may be extended to the inclusion of the vessel together with its motion forwards, evidently with all rotational motion excluded. Therefore since u , v and w shall be functions of the time t only, the first equation may be stated

$$\left(\frac{du}{dx}\right) + \left(\frac{dv}{dy}\right) + \left(\frac{dw}{dz}\right) = 0,$$

to be satisfied at once; then for the other equation, on account of

$$U = \left(\frac{du}{dt}\right), \quad V = \left(\frac{dv}{dt}\right), \quad W = \left(\frac{dw}{dt}\right),$$

and thus since these will be functions of t only, we will have

$$\frac{2gd\rho}{b} = 2gdS - dx\left(\frac{du}{dt}\right) - dy\left(\frac{dv}{dt}\right) - dz\left(\frac{dw}{dt}\right),$$

in which the time t is assumed constant. Whereby since the formula $dS = Pdx + Qdy + Rdz$ shall be integrable, also this equation will be allowed to be integrable, also this equation will be allowed to be integrated and the assumed motion will be able to be present: and there will become

$$\frac{2gp}{b} = 2gS - x\left(\frac{du}{dt}\right) - y\left(\frac{dv}{dt}\right) - z\left(\frac{dw}{dt}\right) + f : t.$$

Therefore provided that the extrinsic forces acting both on the vessel as well as on the fluid were prepared thus, so that they would produce such a motion in a solid body, also the fluid will receive the same motion; and since that can be done in an infinite number of ways, if indeed in addition two forces equal and opposite to these forces always may be allowed to act, if one of these other forces likewise may act on the fluid with the aid of a piston, the pressure in the fluid can be changed at once arbitrarily, which change will be contained in that arbitrary function $f: t$. From which it is certainly evident to be able to happen, that the fluid mass may be carried forwards by a prescribed motion, and external forces for this requirement may be found in some way, so that the pressure through the whole mass to be allowed to be assigned at some time, which in this case will depend not only on the action S , but also on the coordinates x, y, z .

COROLLARY 1

61. Therefore if the fluid may be considered to include the vessel, so that the vessel may be carried forwards by that motion, which the speeds u, v, w may designate, the fluid will be at rest with respect to the vessel and will be able to be considered as if with that to constitute a solid body.

COROLLARY 2

62. Yet this will not depend on opposing pressures in the fluid, in whatever manner they may be able to be varied, while in the first place from the action of the forces S , which certainly will depend on the position, then truly also on the three variables x, y, z , which also are changed continually for the same element of the fluid; and this latter change is required to be considered to arise from a failure of the uniform motion.

COROLLARY 3

63. Moreover besides these changes, which may come about both from the action of the forces as well as from the inequality of the motion, if the pressure may be varied in any way at any successive times. Yet meanwhile for any time, if the pressure may be agreed on at one place, it will be able to be assigned in all the remaining places.

SCHOLIUM

64. Therefore while the forces acting P, Q, R may be prepared thus, so that the formula $Pdx + Qdy + Rdz$ may be allowed to be integrated, all the fluid mass can receive a forwards motion, just as happens for solid bodies, but only if the density of the fluid were constant and no change may appear from the forces acting. Truly also whether it may thence be

able for a rotational motion to be carried forwards as a solid body, hence is not yet apparent ; and we reserve that investigation to the following chapter, where indeed we will explore this argument more generally; indeed since for a solid body rotating about a fixed axis the speeds shall be proportional to the distances themselves from the axes, in a fluid also other proportions can be used, since here there is no necessity for the forces to act, so that the individual elements may complete their revolutions in the same time. But in this chapter cases of this kind remain to be considered carefully, in which a certain agreement is to be prescribed regarding the three speeds, while any of these whatsoever is assumed variable; motion of whatever kind, since it will differ greatly from the motion of solids, will be our concern especially, on being elucidated by our principles.

PROBLEM 30

65. *If the speeds of any three points whatever u, v, w everywhere and always maintain a constant ratio between themselves, the conditions are to be examined carefully, under which such motion may be able to exist, so that meanwhile the individual elements of the fluid may be acted on by whatever forces P, Q, R .*

SOLUTION

Because the three speeds u, v, w maintain a constant ratio among themselves, the individual elements of fluid will be moving along the same direction, with some variable speed; it will required to investigate whether a motion may be allowed, and under which conditions. Therefore with the new variable introduced ϑ [Instead of this zodiacal sign, here the old Germanic capital letter \mathfrak{T} will be used for convenience], which shall be some function of the four quantities x, y, z and t , we may put

$$u = \alpha \mathfrak{T}, \quad v = \beta \mathfrak{T}, \quad \text{and} \quad w = \gamma \mathfrak{T},$$

where α, β, γ shall be constant quantities, and so that the first equation may be satisfied, there shall be required to be:

$$\alpha \left(\frac{d\mathfrak{T}}{dx} \right) + \beta \left(\frac{d\mathfrak{T}}{dy} \right) + \gamma \left(\frac{d\mathfrak{T}}{dz} \right) = 0.$$

Moreover since there shall be

$$d\mathfrak{T} = dx \left(\frac{d\mathfrak{T}}{dx} \right) + dy \left(\frac{d\mathfrak{T}}{dy} \right) + dz \left(\frac{d\mathfrak{T}}{dz} \right),$$

there will be

$$\alpha d\mathfrak{T} = -\beta dx \left(\frac{d\mathfrak{T}}{dy} \right) - \gamma dx \left(\frac{d\mathfrak{T}}{dz} \right) + \alpha dy \left(\frac{d\mathfrak{T}}{dy} \right) + \alpha dz \left(\frac{d\mathfrak{T}}{dz} \right)$$

or

$$\alpha d\mathfrak{T} = (\alpha dy - \beta dx) \left(\frac{d\mathfrak{T}}{dy} \right) + (\alpha dz - \gamma dx) \left(\frac{d\mathfrak{T}}{dz} \right),$$

for which equation to be satisfied it is understood, in a similar manner \mathfrak{T} shall be a function of the two variables

$$(\alpha y - \beta x) \text{ and } (\alpha z - \gamma x), \text{ or, of these } \left(\frac{x}{\alpha} - \frac{y}{\beta}\right) \text{ and } \left(\frac{x}{\alpha} - \frac{z}{\gamma}\right),$$

to which also the third variable t can be added on. Indeed if \mathfrak{T} shall be some function of the three variables

$$\left(\frac{x}{\alpha} - \frac{y}{\beta}\right), \left(\frac{x}{\alpha} - \frac{z}{\gamma}\right) \text{ and } t,$$

which differentiated will give :

$$d\mathfrak{T} = L\left(\frac{dx}{\alpha} - \frac{dy}{\beta}\right) + M\left(\frac{dx}{\alpha} - \frac{dz}{\gamma}\right) + Ndt,$$

and where there will be

$$\left(\frac{d\mathfrak{T}}{dx}\right) = \frac{1}{\alpha}L + \frac{1}{\alpha}M, \quad \left(\frac{d\mathfrak{T}}{dy}\right) = -\frac{1}{\beta}L \quad \text{and} \quad \left(\frac{d\mathfrak{T}}{dz}\right) = -\frac{1}{\gamma}M,$$

from which certainly there shall become

$$\alpha\left(\frac{d\mathfrak{T}}{dx}\right) + \beta\left(\frac{d\mathfrak{T}}{dy}\right) + \gamma\left(\frac{d\mathfrak{T}}{dz}\right) = 0$$

With such a function established for \mathfrak{T} there will be deduced :

$$U = \alpha\alpha\mathfrak{T}\left(\frac{d\mathfrak{T}}{dx}\right) + \alpha\beta\mathfrak{T}\left(\frac{d\mathfrak{T}}{dy}\right) + \alpha\gamma\mathfrak{T}\left(\frac{d\mathfrak{T}}{dz}\right) + \alpha\left(\frac{d\mathfrak{T}}{dt}\right),$$

which on account of

$$\alpha\left(\frac{d\mathfrak{T}}{dx}\right) + \beta\left(\frac{d\mathfrak{T}}{dy}\right) + \gamma\left(\frac{d\mathfrak{T}}{dz}\right) = 0$$

will become $\alpha\left(\frac{d\mathfrak{T}}{dt}\right)$, and in a like manner there will become

$$V = \beta\left(\frac{d\mathfrak{T}}{dt}\right) \quad \text{and} \quad W = \gamma\left(\frac{d\mathfrak{T}}{dt}\right).$$

On account of which the other equation found for the motion of the fluid thus will be obtained by considering the time t constant:

$$\frac{2gdp}{b} = 2gdS - (\alpha dx + \beta dy + \gamma dz)\left(\frac{d\mathfrak{T}}{dt}\right),$$

which, if the formula $dS = Pdx + Qdy + Rdz$ shall be integrable, to require absolutely, so that the other part also $(\alpha dx + \beta dy + \gamma dz) \left(\frac{d\mathfrak{T}}{dt} \right)$ may be allowed to be integrated ; which cannot happen, unless $\left(\frac{d\mathfrak{T}}{dt} \right)$ shall be a function of the two variables $\alpha dx + \beta dy + \gamma dz$

$\alpha x + \beta y + \gamma z$ and t , which since it cannot exist unless $\left(\frac{d\mathfrak{T}}{dt} \right)$ shall be a function of the time t alone. On account of which the quantity \mathfrak{T} must be prepared thus, so that there shall be

$$\mathfrak{T} = \text{function} : \left(\left(\frac{x}{\alpha} - \frac{y}{\beta} \right) \text{ and } \left(\frac{x}{\alpha} - \frac{y}{\gamma} \right) \right) + \mathfrak{T} : t,$$

so that there may become $\left(\frac{d\mathfrak{T}}{dt} \right) = \mathfrak{T}' : t$; then moreover there will be found :

$$\frac{2gp}{b} = 2gS - (\alpha x + \beta y + \gamma z) \mathfrak{T}' : t + \Delta : t$$

with there being $\mathfrak{T}' : t = \frac{d \cdot \mathfrak{T} : t}{dt}$.

COROLLARY 1

66. Therefore the element of the fluid at Z will be moved with the speed, which is

$$= \mathfrak{T} \sqrt{(\alpha\alpha + \beta\beta + \gamma\gamma)},$$

and its direction is inclined to the axis OA by the angle, of which the cosine

$$= \frac{\alpha}{\sqrt{\alpha\alpha + \beta\beta + \gamma\gamma}},$$

to the axis OB by the angle, of which the cosine

$$= \frac{\beta}{\sqrt{\alpha\alpha + \beta\beta + \gamma\gamma}},$$

and to the axis OC by the angle, of which the cosine

$$= \frac{\gamma}{\sqrt{\alpha\alpha + \beta\beta + \gamma\gamma}}.$$

COROLLARY 2

67. Therefore since the motion everywhere and always shall be in the same direction, all the elements of the fluid will be brought forwards along right lines parallel to each other. But the speed will be able to be maximally variable both on account of the position as well as of the time, provided that \mathfrak{T} shall be a function of this kind, such as we have described.

COROLLARY 3

68. Moreover the greatest variety can be found here, since some function of these two quantities $\frac{x}{\alpha} - \frac{y}{\beta}$ and $\frac{x}{\alpha} - \frac{z}{\gamma}$ is allowed to be taken for \mathfrak{T} , and may be added to some function of the time above.

COROLLARY 4

69. From the above it is apparent that the letters U, V, W express the accelerations of the motions along the directions of the x, y, z , from which if there were $\mathfrak{T} : t = 0$ and thus $\left(\frac{d\mathfrak{T}}{dt}\right) = 0$, these accelerations vanish, and any element will be progressing uniformly in the direction.

SCHOLIUM

70. Here a motion may be taken resembling that well enough, by which rivers may be advancing; for if gravity alone may act on the water along ZY downwards, there will become

$$P = 0, \quad Q = 0 \quad \text{and} \quad R = -1, \quad \text{and thus} \quad S = -z,$$

and if again the function depending on the time may vanish, so that there shall become

$$\mathfrak{T} = \text{funct.} : \left(\left(\frac{x}{\alpha} - \frac{y}{\beta} \right) \text{ and } \left(\frac{x}{\alpha} - \gamma \right) \right), \quad \text{and} \quad p = b(a - z),$$

and thus the pressure vanishes on the horizontal plane for the height $z = a$ [Thus, Euler does not consider the atmospheric pressure, but only the hydrostatic pressure of the water]. Nor truly is it necessary, that the direction of the water shall be horizontal, but the motion can exist, even if the liquid may be carried either upwards or downwards, or if it may maintain some oblique course, which indeed can be considered with difficulty, since the water must be able to pass through its own surface. Here truly another inconvenience arises, because water moving beyond the height a will emerge with a negative pressure, and thus the continuity of the water may be missing and that water may be scattered as if into drops. But I have warned from the beginning, that this principle which I have stated firmly, for the continuity of the water thus to depend on, so that, where that will have ceased, the situation cannot be considered further: from which cases of this kind, where the continuous coherence of the fluid may have ceased, hence are required to be abandoned. Concerning the remainder, where we have declared this motion as possible, thus it is required to understand that forces of this kind are able to be given always, by whose action that motion may be obtained. Truly the more general problems treated here can be proposed and resolved in the following way.

PROBLEM 31

71. If the three speeds u , v , w of each fluid element may be able to be prepared thus, so that there shall be:

$$u = \alpha\mathfrak{T} + \Gamma : t, \quad v = \beta\mathfrak{T} + \Delta : t, \quad \text{and} \quad w = \gamma\mathfrak{T} + \Sigma : t$$

with \mathfrak{T} denoting some function, the conditions are to be examined closely, under which some motion can be consistent, while the individual elements of the fluid may be acted on by some forces P , Q , R .

SOLUTION

Here and likewise as in the preceding problem the first general equation may demand, so that \mathfrak{T} shall be a function of these two quantities $\frac{x}{\alpha} - \frac{y}{\beta}$ and $\frac{x}{\alpha} - \frac{z}{\gamma}$, neither now is there a need for some function of the time t to be added to that, since now such indefinite functions of the three speeds shall be added into the hypothesis.

Therefore since hence there may become

$$\alpha \left(\frac{d\mathfrak{T}}{dx} \right) + \beta \left(\frac{d\mathfrak{T}}{dy} \right) + \gamma \left(\frac{d\mathfrak{T}}{dz} \right) = 0$$

there will be obtained

$$U = \left(\frac{du}{dt} \right) = \Gamma' : t, \quad V = \Delta' : t \quad \text{and} \quad W = \Sigma' : t$$

and thus with the action of the forces $\int (Pdx + Qdy + Rdz) = S$ the equation declaring the state of the pressure will become:

$$\frac{2gp}{b} = 2gS - x\Gamma' : t - y\Delta' : t - z\Sigma' : t + \Pi' : t.$$

COROLLARY 1

72. This problem appeared much broader than the preceding, since not only can the direction of the motion at the same point be varied greatly with the passage of time, but also in different elements of the fluid in that same time, the direction of the motion may be shown to be different.

COROLLARY 2

73. Moreover in the same time, where the functions $\Gamma : t$, $\Delta : t$, $\Sigma : t$ may be allocated the same values through the whole mass of the fluid, since \mathfrak{T} will depend on the location Z , at different point not only the speed but also the direction of the motion will be able to be varied: yet everywhere $\frac{u}{\alpha} - \frac{v}{\beta}$ and $\frac{u}{\alpha} - \frac{w}{\gamma}$ will maintain the same values.

SCHOLIUM

74. But this motion differs so far from the flowing of rivers ; for if we may wish the formulas found here to apply to these, so that in the first place the same motion may always be produced at the same point, the functions of time $\Gamma : t, \Delta : t, \Sigma : t$ must denote constant quantities, but then on account of $S = -z$ there will become $p = b(a - z)$, and thus the pressures will vanish on a certain horizontal plane. Therefore no vertical motion will be able to be attributed to the fluid particles, since otherwise particles of fluid will have to be allowed above the highest surface, where there shall become $w = 0$ and thus both $\gamma = 0$ and $\Sigma : t = 0$, from which the individual elements of the liquid will be moving in horizontal planes, nor therefore will any declivity be found here, which yet are distinctive properties of rivers. From which investigation the motion of rivers is a matter requiring to be judged from a much higher degree of understanding. Yet meanwhile we discern here an example of this kind of river, where the individual particles of which are moved forwards by a horizontal motion, but the direction of which as well as the speed shall be variable everywhere. Yet this does not prevent the pressure everywhere from depending only on the depth evidently in the same manner, as if the water may lie in pools. But since in this case there shall be $y = 0$, \mathfrak{T} shall be some function of the two quantities $\left(\frac{x}{\alpha} - \frac{y}{\beta}\right)$ and z , and thus the same will be found for all the points in any horizontal plane, where $\frac{x}{\alpha} - \frac{y}{\beta}$ will have the same value, that is, with all the right lines inclined to the axis OA by an angle, of which the tangent $= \frac{\beta}{\alpha}$, and which therefore will be parallel to each other : and all the particles of the water will be carried forwards situated on such right lines with an equal motion: nor truly will they progress along this right line itself, since on putting $\mathfrak{T} : t = m$ and $A : t = n$, the speeds of which are going to become $u = \alpha\mathfrak{T} + m$ and $v = \beta\mathfrak{T} + n$, indeed from which the speeds may be equal, but the directions will differ from that line, unless there shall be $m : n = \alpha : \beta$. Therefore while in this manner the parallel lines may be transferred from this directly into other lines parallel to each other, where both will give the same speed as well as directions, it is clear it can happen, that the individual elements of the liquid may be changed into an especially uneven motion with curved lines. From which if the path of each particle in a horizontal plane shall be required to be defined with the aid of the equations between the two coordinates x and y , on account of

$$dx = dt(\alpha\mathfrak{T} + m) \text{ and } dy = dt(\beta\mathfrak{T} + n)$$

on eliminating dt there becomes

$$\mathfrak{T}(\beta dx - \alpha dy) + ndx - mdy = 0.$$

Truly because here the depth z remains the same, \mathfrak{T} will be a function of $\frac{x}{\alpha} - \frac{y}{\beta}$, or of $\beta x - \alpha y$, for which by writing $\Theta' : (\beta x - \alpha y)$ there will become

$$nx - my + \Theta : (\beta x - \alpha y) = \text{Const.}$$

Therefore the function Θ can be taken thus, so that it may produce the given curve, which for the external particles referred to, will represent the shape of the bank defining the river and thus for the individual depths for an arbitrary shape of the bank, and therefore the trough of the whole river bed will be able to be formed.

SECTIO SECUNDA DE PRINCIPIIS MOTUS FLUIDORUM

Commentatio 396 indicis ENESTROEMIANI

Novi commentarii academiae scientiarum Petropolitanae 14 (1769): I, 1770, p. 270-386

CAPUT I

CONSIDERATIO MOTUS FLUIDORUM IN GENERE

PROBLEMA 17

1. *Si massa fluida in motu quocunque versetur, elementa exponere, ex quibus eius statum et motum ad quodvis tempus commodissime cognoscere et ad calculum revocare liceat.*

SOLUTIO

Referantur (Fig. 22) singula fluidi elementa ad ternos axes fixos inter se normales OA , OB et OC , ita ut cuiusque elementi in Z siti locus per ternas coordinatas illis axibus parallelas determinetur, quae sint $OX = x$, $XY = y$ et $YZ = z$: et cum fluidum in motu sit constitutum, id elementum consideremus, quod nunc, postquam datum tempus $= t$ a certa epocha effluxerit, in puncto Z versetur, quandoquidem labente tempore

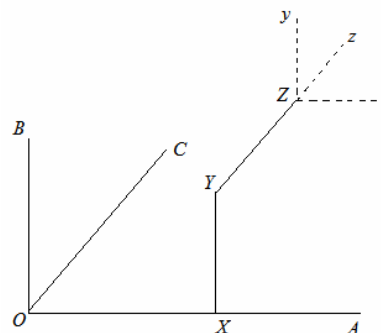

Fig. 22

alia atque alia fluidi elementa per idem punctum Z transeunt. Iam ad statum fluidi praesentem cognoscendum, si eius densitas variationis sit capax, primo densitas fluidi in puncto Z est definienda, quam littera q designemus, quae cum non solum pro diverso situ puncti Z , sed etiam pro diverso tempore, diversa esse possit, hanc quantitatem q tanquam functionem quatuor variabilium x, y, z et t spectari oportet, in qua si pro t tempus propositum scribatur, loco x, y et z vero eae tres coordinatae OX, XY, YZ , quae puncto Z conveniunt, ipsa densitas fluidi in Z ad tempus propositum obtinetur. Sin autem densitas fluidi ubique et perpetuo sit eadem, littera q denotabit quantitatem constantem.

Secundo loco etiam pressionem in loco Z cognitam esse oportet, quae exprimatur altitudine $= p$, quae scilicet tribui debet columnae ex materia homogenea, cuius densitas $= 1$, constanti, ut eius pondus pressioni aequali basi innitenti fiat aequale, ac pro ratione huius densitatis unitate expressae perpetuo illa densitas q sit mensuranda. Cum igitur et haec altitudo pro varietate loci ac temporis diversa esse possit, etiam p ut functio quatuor variabilium x, y, z et t tractari debet.

Tertio, si fluidum actioni virium veluti gravitatis aliarumque similium, sit subiectum, eas semper in ternas secundum directiones coordinatarum resolvere licet. Sint ergo hae vires acceleratrices elementum in Z situm sollicitantes secundum directionem $Zx = P$, secundum directionem $Zy = Q$ et secundum directionem $Zz = R$, posita vi gravitatis naturalis $= 1$. Hae vires, si sint variables, tantum ab loco puncti Z , non vero a tempore t pendere solent.

Quarto, pro motus cognitione imprimis necesse est motum cuiusque elementi ad quodvis tempus nosse, qui motus convenientissime secundum directiones trium axium resolvitur. Sit ergo pro tempore $= t$ elementi in Z versantis celeritas secundum directionem $Zx = u$, secundum directionem $Zy = v$ et secundum $Zz = w$, quae ergo ternae celeritates tanquam functiones quatuor variabilium x, y, z et t spectari debent. Ubi facile patet calculum ita instrui posse, ut tempus t in minutis secundis, celeritates autem u, v, w per spatia uno minuto secundo percurrenda exprimantur.

COROLLARIUM 1

2. Cognitio ergo perfecta status et motus fluidorum his quatuor capitibus, quae exposuimus, continetur, densitate scilicet, pressione, viribus sollicitantibus et ternis cuiusque elementi celeritatibus, quae si ad quodvis tempus assignare valeamus, perfectam totius motus cognitionem habebimus.

COROLLARIUM 2

3. Vires quidem, quibus fluidum sollicitatur, semper ultro dantur, neque ipsae a motu pendent: ita, etiamsi motus sit incognitus, vires P, Q, R , quibus singula elementa incitantur, inter quantitates cognitae sunt referendae, atque ex iis potissimum reliqua capita determinationem nanciscuntur.

COROLLARIUM 3

4. Quando fluidum est homogeneous eiusque densitas nulli variationi obnoxia, etiam quantitas q erit data, sin autem sit sive heterogeneous, sive quaelibet particula densitatem habeat variabilem, omnino necessarium est, ut durante motu pro quovis puncto Z particulae ibi versantis densitas investigetur.

COROLLARIUM 4

5. Tota ergo theoria motus fluidorum huc redit, ut pro data fluidi natura et viribus sollicitantibus quantitates q, p, u, v, w definiantur ac per quatuor variables x, y, z et t ita exprimantur, ut earum valores tam pro quovis puncto Z quam quovis tempore t assignari queant.

SCHOLION 1

6. Cum hae quantitates q, p, u, v, w ut functiones harum quatuor variabilium x, y, z et t tractari debeant, cuiusque differentiale in genere sumtum ita exprimetur:

$$dq = dx \left(\frac{dq}{dx} \right) + dy \left(\frac{dq}{dy} \right) + dz \left(\frac{dq}{dz} \right) + dt \left(\frac{dq}{dt} \right)$$

cuius formae tres partes priores incrementum densitatis, quae nunc in Z statuitur = q , exhibent, dum manente tempore t eodem ad aliud punctum ipsi Z proximum transimus, cuius locus his ternis coordinatis $x + dx, y + dy, z + dz$ determinatur, sicque intelligitur, quomodo tempore t constanti assumto pro quovis instanti per totam fluidi massam in singulis punctis densitas se sit habitura, quod simili modo de pressione et ternis celeritatibus singulorum elementorum est intelligendum, atque hoc quidem ex natura differentialium per se est manifestum. At si manentibus coordinatis x, y et z iisdem tempus t differentiali suo dt augetur, densitas iam fiet $q + dt \left(\frac{dq}{dt} \right)$, quae autem neutiquam eius elementi fluidi, quod in Z haeserat, densitatem tempusculo dt variatam praebet, quemadmodum non satis attendenti videri posset, sed ea formula potius alius elementi, quod demum elapso tempusculo dt per punctum Z transibit, densitatem declarabit. Quando autem eiusdem elementi fluidi, quod in Z versabatur et cuius densitas erat = q , densitatem tempusculo dt variatam definire velimus, ante omnia ad locum, ubi hoc elementum post tempusculum dt haerebit, respicere debemus, qui si his coordinatis variatis $x + dx, y + dy, z + dz$ indicetur, verum densitatis incrementum erit

$$dx \left(\frac{dq}{dx} \right) + dy \left(\frac{dq}{dy} \right) + dz \left(\frac{dq}{dz} \right) + dt \left(\frac{dq}{dt} \right).$$

Haecque eadem cautio adhibenda est, si eiusdem fluidi elementi, quod nunc in Z versatur, elapso tempusculo dt sive pressionem sive motum ternis celeritatibus u, v, w determinatum assignare debemus. Quae cautio eo magis est necessaria et omni cura inculcanda, quod ea ob attentionis defectum neglecta in gravissimos errores incidere possemus.

SCHOLION 2

7. Ad motum porro fluidi cognoscendum omnino necesse est eius elementorum motus nosse, minimeque sufficit, uti in corporibus solidis usu venire solet, aliquot tantum punctorum motum investigasse. In motu scilicet corporum solidorum rigidorum, statim ac trium punctorum non in directum sitorum motus innotuerit, inde simul omnium reliquorum punctorum totius corporis motus definitur; ac si corpus flexuris sit praeditum, plurium quidem punctorum motus ad totius corporis motum definiendum requiritur, eorum tamen numerus semper est finitus. In fluidis autem singula elementa motu peculiari ferri possunt, ita ut, etiamsi mille particularum motum exploratum haberemus, totus tamen motus iis nondum sit determinatus. Neque tamen omnium elementorum motus ideo neutiquam a se mutuo pendere sunt censendi, quodsi enim densitas fluidi nullam mutationem patiat, evidens est singulas particulas non ita temere profluere posse, ut vel in maius spatium dispergantur, vel in minus compellantur, unde certa quaedam conditio inter singularum particularum motus stabilitur. At etiamsi fluidum condensationis et rarefactionis sit capax, tamen talis mutatio non sine respectu ad pressionem habito evenire nequit, ex quo ob pressionem omnes omnium particularum motus certa quadam lege limitantur. Haec autem ipsa limitatio in theoria motus fluidorum praecipuum caput constituit quod eo reduci facile perspicitur, ut motu omnium elementorum ut cognito spectato, variatio cum densitatis tum motus cuiusque puncti investigetur.

SCHOLION 3

8. Quatuor illa capita, quibus perfectam notitiam motus fluidorum contineri diximus, fortasse huic scopo nondum sufficere videbuntur, quoniam plerumque ad plures alias circumstantias attendi necesse est, veluti si fluidum vasi sit inclusum, per quod vel transfluat vel ex quo effluat, ad quodvis tempus quoque nosse oportet, quousque fluidum in vase porrigatur, simulque vasis figuram probe perspectam esse oportet: tum si qua in parte fluidum sit apertum, ubi scilicet pressio fuerit nulla, etiam haec circumstantia ad motum ulteriorem determinandum omnino necessaria videtur. Verum hic in genere tantum est tenendum quatuor exposita capita omnino sufficere ad motum aequationibus differentialibus includendum, in quo principiorum motus vis potissimum consistit. His autem aequationibus inventis, quando eas integrari oportet, tum demum omnes illae circumstantiae in computum ingrediuntur atque analysis semper ita ad omnes casus accommodata deprehenditur, ut omnibus illis conditionibus, quascunque circumstantiae praescribunt, semper perfecte satisfieri possit.

PROBLEMA 18

9. *Datis celeritatibus u , v et w , quibus singula fluidi elementa moventur, investigare translationem cuiuscunque moleculae fluidi tempusculo infinite parvo dt factam.*

SOLUTIO

Moleculae (Fig. 23) cuius translationem quaerimus, tribuamus figuram pyramidis triangularis $ZLMN$, pro cuius quatuor angulis sint ternae coordinatae:

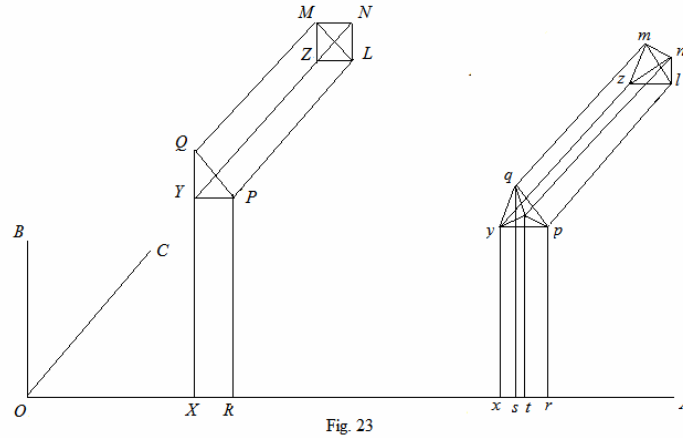

$$\begin{aligned}
 \text{Pro } Z \quad & OX = x, \quad XY = y, \quad YZ = z \\
 \text{Pro } L \quad & OR = x + dx, \quad RP = y, \quad PL = z \\
 \text{Pro } M \quad & OX = x, \quad XY = y + dy, \quad QM = z \\
 \text{Pro } N \quad & OX = x, \quad XY = y, \quad YN = z + dz.
 \end{aligned}$$

Cum nunc pro puncto Z sint celeritates secundum directiones ternis axibus parallelas u, v, w functiones quatuor variabilium x, y, z et t , hinc pro singulis angulis hae celeritates ita se habebunt

	celeritas	celeritas	celeritas
Pro Z	secundum $OA = u,$	sec. $OB = v,$	sec. $OC = w$
Pro L	sec. $OA = u + dx\left(\frac{du}{dx}\right),$	sec. $OB = v + dx\left(\frac{dv}{dx}\right),$	sec. $OC = w + dx\left(\frac{dw}{dx}\right)$
Pro M	sec. $OA = u + dy\left(\frac{du}{dy}\right),$	sec. $OB = v + dy\left(\frac{dv}{dy}\right),$	sec. $OC = w + dy\left(\frac{dw}{dy}\right)$
Pro N	sec. $OA = u + dz\left(\frac{du}{dz}\right),$	sec. $OB = v + dz\left(\frac{dv}{dz}\right),$	sec. $OC = w + dz\left(\frac{dw}{dz}\right)$

His ergo celeritatibus tempusculo dt haec quatuor puncta Z, L, M, N transferentur in z, l, m, n , quae sequentibus, ternis coordinatis determinabuntur:

$$\begin{aligned}
Ox &= x + udt, & xy &= y + vdt, \\
Or &= x + dx + udt + dtdx\left(\frac{du}{dx}\right), & yz &= z + wdt \\
Os &= x + udt + dtdy\left(\frac{du}{dy}\right), & rp &= y + vdt + dtdx\left(\frac{dv}{dx}\right), \\
Ot &= x + udt + dtdz\left(\frac{du}{dz}\right), & pl &= z + w + dtdx\left(\frac{dw}{dx}\right) \\
& & sq &= y + dy + vdt + dtdy\left(\frac{dv}{dy}\right), \\
& & qm &= z + wdt + dtdy\left(\frac{dw}{dy}\right) \\
& & to &= y + vdt + dtdz\left(\frac{dv}{dz}\right), \\
& & on &= z + dz + wdt + dtdz\left(\frac{dw}{dz}\right).
\end{aligned}$$

Fluidi ergo materia in pyramide $ZLMN$ contenta ita movetur, ut elapso tempusculo dt pyramidem $zlmn$ occupet et impleat. Quoniam enim pyramis $ZLMN$ est infinite parva, utcunque motus fuerit irregularis, omnia puncta in singulis hedris pyramidis $ZLMN$ contenta ita moveri necesse est, ut perpetuo secundum hedras planas maneant disposita, sicque hedra ZLM in zlm pervenire est censenda, similique modo de reliquis.

COROLLARIUM 1

10. Etiam si ergo forte figura moleculae pyramidis $ZLMN$ mutatur, tamen figuram pyramidis triangularis retinet, unde cum quaelibet molecula in huiusmodi pyramides resolvi queat, eius quoque figura, quae ipsi ob motum inducitur, hinc colligi poterit.

COROLLARIUM 2

11. Cum latera pyramidis $ZLMN$ principalia sint $ZL = dx$, $ZM = dy$ et $ZN = dz$, quae inter se sunt normalia, reliqua erunt

$$LM = \sqrt{(dx^2 + dy^2)}, \quad LN = \sqrt{(dx^2 + dz^2)}, \quad \text{et} \quad MN = \sqrt{(dy^2 + dz^2)}$$

$$ZN = dz$$

atque soliditas istius pyramidis erit $= \frac{1}{6} dx dy dz$, cum basis ZLM area sit $= \frac{1}{2} dx dy$ et altitudo $ZN = dz$.

SCHOLIUM 1

12. Nunc ergo quoque singula latera pyramidis translatae $zlmn$ definire poterimus. Primo enim ob

$$Or - Ox = dx + dtdx\left(\frac{du}{dx}\right), \quad rp - xy = dtd\left(\frac{dv}{dx}\right), \quad pl - yz = dtdx\left(\frac{dw}{dx}\right)$$

erit $dx + dt dx \left(\frac{du}{dx} \right)$

$$zl = \sqrt{\left(dx^2 + 2dt dx^2 \left(\frac{du}{dx} \right) \right)} = dx + dt dx \left(\frac{du}{dx} \right),$$

quia particulas post signum radicale, ubi differentialia ad quatuor dimensiones assurgunt, reicere licet; simili modo erit

$$zm = dy + dt dy \left(\frac{dv}{dy} \right) \quad \text{et} \quad zn = dz + dt dz \left(\frac{dw}{dz} \right),$$

deinde pro latere lm ob

$$Or - Os = dx + dt dx \left(\frac{du}{dx} \right) - dt dy \left(\frac{du}{dy} \right)$$

$$sq - rp = dy - dt dx \left(\frac{dv}{dx} \right) + dt dy \left(\frac{dv}{dy} \right)$$

$$qm - pl = -dt dx \left(\frac{dw}{dx} \right) + dt dy \left(\frac{dw}{dy} \right)$$

$$\text{fiet } lm = \sqrt{\left(dx^2 + dy^2 + 2dt dx^2 \left(\frac{du}{dx} \right) - 2dt dx dy \left(\frac{du}{dx} \right) - 2dt dx dy \left(\frac{dv}{dx} \right) + 2dt dy^2 \left(\frac{dv}{dy} \right) \right)}$$

seu

$$lm = \sqrt{\left(dx^2 + dy^2 \right)} + \frac{dt dx^2 \left(\frac{du}{dx} \right) - dt dx dy \left(\frac{du}{dy} \right) - dt dx dy \left(\frac{dv}{dx} \right) + dt dy^2 \left(\frac{dv}{dy} \right)}{\sqrt{\left(dx^2 + dy^2 \right)}}.$$

Hinc autem commodius angulus lzm definitur, cum enim sit

$$\cos lzm = \frac{zl^2 + zm^2 - lm^2}{2zl \cdot zm},$$

reperitur

$$\cos lzm = \frac{2dt dx dy \left(\left(\frac{du}{dy} \right) + \left(\frac{dv}{dx} \right) \right)}{2dx dy} = dt \left(\frac{du}{dy} \right) + dt \left(\frac{dv}{dx} \right),$$

qui ergo angulus infinite parum a recto discrepat, simili autem modo invenitur

$$\cos lzn = dt \left(\frac{du}{dz} \right) + dt \left(\frac{dw}{dx} \right) \quad \text{et} \quad \cos mzn = dt \left(\frac{dv}{dz} \right) + dt \left(\frac{dw}{dy} \right),$$

unde patet sinus horum angulorum tam prope ad sinum totum accedere, ut defectus formulis differentialibus secundi gradus exprimatur.

SCHOLION 2

13. Si quaestio esset de motu corporum solidorum, quorum elementa ita sunt comparata, ut neque in quantitate sua neque in figura ullam mutationem admittant, pyramis $zlmn$

omnino similis et aequalis esse deberet pyramidi $ZLMN$, unde laterum principalium aequalitas has suppeditaret aequationes

$$\left(\frac{du}{dx}\right) = 0, \quad \left(\frac{dv}{dy}\right) = 0, \quad \left(\frac{dw}{dz}\right) = 0,$$

reliquorum vero laterum aequalitas has

$$\left(\frac{du}{dy}\right) + \left(\frac{dv}{dx}\right) = 0, \quad \left(\frac{du}{dz}\right) + \left(\frac{dw}{dx}\right) = 0, \quad \left(\frac{dv}{dz}\right) + \left(\frac{dw}{dy}\right) = 0.$$

Quocirca pro corporibus solidis hae tres celeritates u , v , w cuiusque puncti necessario tales functiones quatuor variabilium x , y , z et t esse debent, ut sex istae conditiones locum habeant. Ex ternis prioribus quidem sequitur celeritatem u ab x pendere non posse, neque v

ab y , neque w a z . Deinde cum sit $\left(\frac{du}{dy}\right) = -\left(\frac{dv}{dx}\right)$, hinc sequitur formulam $udx - vdy$

integrabilem esse debere, siquidem solae x et y ut variables spectentur, tum vero eodem modo has formulas differentiales $udx - wdz$ et $vdy - wdz$ integrabiles esse oportebit, ex quibus conditionibus motus corporum solidorum eodem modo determinari reperitur, quo is ex aliis principiis determinari solet. Ex hoc autem casu intelligitur etiam pro fluidis has ternas celeritates certis conditionibus circumscribi debere; si enim fluidum sit eius indolis, ut eius densitas nullam mutationem admittat, tum omnino necesse est, ut pyramidis $zlmn$ volumen aequale sit volumini pyramidis $ZLMN$, ac si densitas variationem patiat, ex ipsa hac variatione volumen pyramidis $zlmn$ determinatur, vicissim autem ex hoc volumine variatio densitatis colligi poterit, unde sequens problema nascitur.

PROBLEMA 19

14. *Datis ternis celeritatibus u , v , w , quibus singula fluidi elementa moventur, investigare variationem densitatis, quam singula elementa, dum tempusculo infinite parvo dt proferuntur, accipiunt.*

SOLUTIO

Consideretur ut ante (Fig. 23) fluidi elementum $ZLMN$, cuius figura densitatis in hoc statu $= q$: positis ternis coordinatis $OX = x$, $XY = y$ et $YZ = z$, sit cum igitur volumen huius pyramidis $= \frac{1}{6} dx dy dz$, massa huius elementi erit $= \frac{1}{6} q dx dy dz$, quae etiam in motu eadem perpetuo manet, quomocunque interea volumen sive augeatur sive minuatur. Ob motum autem, quem huic elemento tribuimus, id tempusculo dt promovetur in $zlmn$, cuius figura itidem pyramidalis, vidimusque eius latera principalia esse:

$$zl = dx + dt dx \left(\frac{du}{dx}\right), \quad zm = dy + dt dy \left(\frac{dv}{dy}\right), \quad zn = dz + dt dz \left(\frac{dw}{dz}\right),$$

angulos autem ad z ita esse comparatos, ut sit

$$\cos lzm = dt\left(\frac{du}{dy}\right) + dt\left(\frac{dv}{dx}\right), \quad \cos lzn = dt\left(\frac{du}{dz}\right) + dt\left(\frac{dw}{dx}\right), \quad \cos mzn = dt\left(\frac{dv}{dz}\right) + dt\left(\frac{dw}{dy}\right),$$

unde volumen huius pyramidis definiri oportet. Quodsi autem brevitatis gratia ponamus

$$\cos lzm = \nu, \quad \cos lzn = \mu \quad \text{et} \quad \cos mzn = \lambda,$$

ex geometria volumen istius pyramidis ita reperitur expressum

$$= \frac{1}{6} zl \cdot zm \cdot zn \sqrt{(1 - \lambda\lambda - \mu\mu - \nu\nu + 2\lambda\mu\nu)}.$$

Quoniam vero λ , μ , ν sunt differentialia primi ordinis, eorum quadrata ad ordinem secundum ascendunt, unde sine errore hoc volumen statuitur $= \frac{1}{6} zl \cdot zm \cdot zn$ sicque erit

$$= \frac{1}{6} dx dy dz \left(1 + dt\left(\frac{du}{dx}\right)\right) \left(1 + dt\left(\frac{dv}{dy}\right)\right) \left(1 + dt\left(\frac{dw}{dz}\right)\right)$$

et facta evolutione reiectisque differentialibus altioribus prodit pyramidis $zlmn$ volumen

$$= \frac{1}{6} dx dy dz \left(1 + dt\left(\frac{du}{dx}\right) + dt\left(\frac{dv}{dy}\right) + dt\left(\frac{dw}{dz}\right)\right);$$

statuatur iam densitas istius pyramidis $= q'$, quae cum per volumen eius multiplicata massam pyramidis $ZLMN$ producere debeat, habebimus hanc aequationem per $\frac{1}{6} dx dy dz$ utrinque dividendo:

$$q = q' + q' dt \left(\left(\frac{du}{dx} \right) + \left(\frac{dv}{dy} \right) + \left(\frac{dw}{dz} \right) \right).$$

Incrementum ergo densitatis $q' - q$ ita exprimitur, ut sit

$$\frac{q' - q}{q' dt} = \frac{q' - q}{q dt} = - \left(\frac{du}{dx} \right) - \left(\frac{dv}{dy} \right) - \left(\frac{dw}{dz} \right).$$

COROLLARIUM 1

15. Si ergo singula fluidi elementa nullam mutationem in densitate sua durante motu patiuntur, ternae celeritates u , v et w eiusmodi debent esse functiones ipsarum x , y , z et t , ut sit

$$\left(\frac{du}{dx} \right) + \left(\frac{dv}{dy} \right) + \left(\frac{dw}{dz} \right) = 0.$$

COROLLARIUM 2

16. Vicissim igitur etiam, quoties fuerit

$$\left(\frac{du}{dx}\right) + \left(\frac{dv}{dy}\right) + \left(\frac{dw}{dz}\right) = 0,$$

per motum singulorum elementorum fluidi densitas non mutatur. Hoc ergo inter alios innumeros casus evenit, si neque u ab x neque v ab y neque w a z pendeat.

COROLLARIUM 3

17. Quoties autem in motu densitas particularum fluidi mutatur, eius variatio ex valore formulae $\left(\frac{du}{dx}\right) + \left(\frac{dv}{dy}\right) + \left(\frac{dw}{dz}\right)$ cognoscitur, qui ubi fuerit positivus, densitas decrescit, ubi autem negativus, ibi densitas augetur.

SCHOLION

18. Methodus hic adhibita volumen pyramidis $zlmn$ investigandi multo est concinnior ac facilior ea, qua olim sum usus in Vol.XI. Mem. Acad. Reg. Boruss. : ubi per multas demum ambages eandem formulam pro isto volumine elicui, dum eius inventionem ad prismata triangularia reduxi. Compendium autem calculi hic inde est ortum, quod tres anguli lzm , lzn , mzn infinite parum ab angulo recto discrepent ac discrimen adeo per quadrata differentialium exprimatur, quod nisi commode usu venisset, altera methodus anteferenda fuisset. Cum scilicet pyramis $zlmn$ aequetur summae horum trium prismatum

$ypozln + yqozmn + poqlmn$, demto quarto $ypqzlm$, erit ea

$$\begin{aligned} &= \frac{1}{3} \Delta ypo (yz + pl + on) + \frac{1}{3} \Delta yqo (yz + qm + on) + \frac{1}{3} \Delta poq (pl + qm + on) \\ &\quad - \frac{1}{3} \Delta ypq (yz + pl + qm), \end{aligned}$$

quae reducitur ad hanc formam

$$\begin{aligned} &\frac{1}{3} (\Delta ypo + \Delta yqo + \Delta poq) (yz + pl + qm + on) \\ &\quad - \frac{1}{3} \Delta ypo \cdot qm - \frac{1}{3} \Delta yqo \cdot pl - \frac{1}{3} \Delta poq \cdot yz \\ &\quad - \frac{1}{3} \Delta ypq (yz + pl + qm + on) + \frac{1}{3} \Delta ypq \cdot on, \\ &\quad - \frac{1}{3} \Delta ypq (yz + pl + qm), \end{aligned}$$

unde ob $\Delta ypq = \Delta ypo + \Delta yqo + \Delta poq$ fit pyramis

$$zlmn = \frac{1}{3} on \cdot \Delta ypq - \frac{1}{3} qm \cdot \Delta ypo - \frac{1}{3} pl \cdot \Delta yqo - \frac{1}{3} yz \cdot \Delta poq.$$

Iam haec triangula porro ita repraesentantur:

$$\begin{aligned} \Delta ypq &= \frac{1}{2} xs(xy + sq) + \frac{1}{2} sr(rp + sq) - \frac{1}{2} xr(xy + rp) \\ &= \frac{1}{2} (xs + rs) (xy + rp + sq) - \frac{1}{2} xs \cdot rp - \frac{1}{2} sr \cdot xy - \frac{1}{2} xr(xy + rp + sq) + \frac{1}{2} xr \cdot sq \end{aligned}$$

ideoque

$$\Delta ypq = \frac{1}{2} xr \cdot sq - \frac{1}{2} xs \cdot rp - \frac{1}{2} sr \cdot xy$$

et simili modo

$$\Delta ypo = \frac{1}{2} xr \cdot to - \frac{1}{2} xt \cdot rp - \frac{1}{2} tr \cdot xy$$

$$\Delta yqo = \frac{1}{2} xt \cdot sq - \frac{1}{2} xs \cdot to - \frac{1}{2} st \cdot xy$$

$$\Delta poq = \frac{1}{2} rt \cdot sq - \frac{1}{2} st \cdot rp - \frac{1}{2} sr \cdot to,$$

ex quibus tandem colligitur

$$\begin{aligned} 6zlmn &= on \cdot xr \cdot sq - on \cdot xs \cdot rp - on \cdot sr \cdot xy \\ &\quad - qm \cdot xr \cdot to + qm \cdot xt \cdot rp + qm \cdot tr \cdot xy \\ &\quad - pl \cdot xt \cdot sq + pl \cdot xs \cdot to + pl \cdot st \cdot xy \\ &\quad - yz \cdot rt \cdot sq + yz \cdot st \cdot rp + yz \cdot sr \cdot to. \end{aligned}$$

Quoniam nunc omnes hae lineae supra sunt definitae, hinc volumen istius pyramidis rationaliter exprimetur, facta autem substitutione haec forma in expressionem succinctam modo inventam contrahitur.

PROBLEMA 20

19. *Datis ternis celeritatibus u , v et w , quibus singula fluidi elementa moventur, investigare accelerationem, quam quodvis elementum tempusculo infinite parvo dt capit.*

SOLUTIO

$$\text{secundum directionem } OA = P - \frac{1}{q} \left(\frac{dp}{dx} \right)$$

$$\text{secundum directionem } OB = Q - \frac{1}{q} \left(\frac{dp}{dy} \right)$$

$$\text{secundum directionem } OC = R - \frac{1}{q} \left(\frac{dp}{dz} \right).$$

Concipiamus (Fig. 24) fluidi elementum iam transiens per punctum Z coordinatis $OX = x$, $XY = y$ et $YZ = z$ determinatum, quod celeritatibus u , v et w latum elapso tempore dt in punctum z perveniat. Hoc ergo punctum istis tribus coordinatis

$$Ox = x + udt, \quad xy = y + vdt \quad \text{et} \quad yz = z + wdt$$

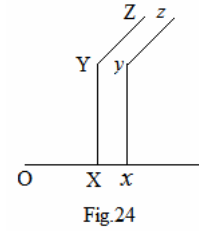

determinabitur. His positis quaeritur, quantum ternae celeritates, quas iam elementum in z habebit et quae sint u' , v' , w' , sint superaturae illas ternas celeritates u , v , w , quas in Z habuerat? quandoquidem ex his incrementis acceleratio est aestimanda. Cum iam u , v et w sint functiones quatuor variabilium x , y , z et t , celeritates quaesitae in z elapso tempusculo dt hinc colligentur, si variables x , y , z et t his incrementis udt , vdt , wdt et dt augeantur: quamobrem colligemus

$$\begin{aligned} u' &= u + udt \left(\frac{du}{dx} \right) + vdt \left(\frac{du}{dy} \right) + wdt \left(\frac{du}{dz} \right) + dt \left(\frac{du}{dt} \right) \\ v' &= v + udt \left(\frac{dv}{dx} \right) + vdt \left(\frac{dv}{dy} \right) + wdt \left(\frac{dv}{dz} \right) + dt \left(\frac{dv}{dt} \right) \\ w' &= w + udt \left(\frac{dw}{dx} \right) + vdt \left(\frac{dw}{dy} \right) + wdt \left(\frac{dw}{dz} \right) + dt \left(\frac{dw}{dt} \right). \end{aligned}$$

Quia igitur in motus investigatione celeritatis incrementum per tempusculum divisum dat accelerationem, ternae accelerationes quaesitae ita se habebunt:

$$\begin{aligned} \frac{u'-u}{dt} &= u \left(\frac{du}{dx} \right) + v \left(\frac{du}{dy} \right) + w \left(\frac{du}{dz} \right) + \left(\frac{du}{dt} \right) \\ \frac{v'-v}{dt} &= u \left(\frac{dv}{dx} \right) + v \left(\frac{dv}{dy} \right) + w \left(\frac{dv}{dz} \right) + \left(\frac{dv}{dt} \right) \\ \frac{w'-w}{dt} &= u \left(\frac{dw}{dx} \right) + v \left(\frac{dw}{dy} \right) + w \left(\frac{dw}{dz} \right) + \left(\frac{dw}{dt} \right). \end{aligned}$$

COROLLARIUM 1

20. Eaedem ergo accelerationes resultare debent ex viribus, quibus idem fluidi elementum sollicitatur, ubi quidem opus est, ut vires sollicitantes secundum easdem ternas directiones resolvantur.

COROLLARIUM 2

21. Singularum ergo celeritatum incrementa etiam a binis reliquis celeritatibus pendent; neque hic vulgari regula in mechanicis usitata uti licet, qua celeritatis u acceleratio per $\frac{du}{dt}$ exprimi solet.

SCHOLION

22. Ratio, quod hic ab ista regula vulgari recedere cogimur, ex praecedentibus, ubi significationem celeritatum u , v , w exposuimus, satis est perspicua. Hae enim celeritates non ita sunt comparatae, ut perpetuo ad idem fluidi elementum referantur, quemadmodum in motu solidorum fieri solet, sed eae hic potius ad idem spatii punctum referuntur, ita ut manentibus coordinatis x , y , z , si solum tempus t variabile statuatur, eae sint praebiturae motum eius elementi, quod elapso tempusculo dt per punctum Z transit. Quare cum hic accelerationes eiusdem elementi, quod nunc in Z , post tempusculum dt vero in z reperitur, desiderentur functiones illas u , v et w , non solum per tempusculum dt , sed etiam a puncto Z in punctum z transferri debent, quarum tum excessus super illas incrementa celeritatum eiusdem elementi fluidi indicabit. In errorem ergo insignem fuissemus prolapsi, si regula illa vulgari decepti has accelerationes simpliciter formulis $\left(\frac{du}{dt}\right)$, $\left(\frac{dv}{dt}\right)$, $\left(\frac{dw}{dt}\right)$ expressissemus, quae, ut nunc videmus, tantum partem aliquam verarum accelerationum constituunt.

PROBLEMA 21

23. Si praeter ternas celeritates u , v , w , quae singulis spatii punctis, per quod fluidum movetur, conveniunt, etiam densitas q in quolibet puncto datur, relationem, quae inter celeritates et densitatem intercedit, investigare.

SOLUTIO

In problemate 19 invenimus, si fluidi particula his celeritatibus u , v , w ex Z in z tempusculo dt proferatur eiusque densitas in Z ponatur $= q$, in z vero $= q'$, tum fore

$$\frac{q'-q}{qdt} = -\left(\frac{du}{dx}\right) - \left(\frac{dv}{dy}\right) - \left(\frac{dw}{dz}\right).$$

Nunc autem, quia densitas q ut functio data quatuor variabilium x , y , z et t spectatur et nunc quidem particulae in puncto Z versantis densitatem denotat, ex ea colligetur densitas q' , si elapso tempusculo dt in punctum z transferatur, sicque quatuor variabilibus x , y , z et t haec incrementa udt , vdt , wdt et dt tribui oportet. Quocirca haec densitas q' eidem particulae ex Z in z translatae conveniens ita exprimetur:

$$q' = q + udt\left(\frac{dq}{dx}\right) + vdt\left(\frac{dq}{dy}\right) + wdt\left(\frac{dq}{dz}\right) + dt\left(\frac{dq}{dt}\right),$$

unde fit

$$\frac{q'-q}{dt} = u\left(\frac{dq}{dx}\right) + v\left(\frac{dq}{dy}\right) + w\left(\frac{dq}{dz}\right) + \left(\frac{dq}{dt}\right),$$

qui valor si in superiori aequatione substituat, ratio quaesita inter celeritates et densitatem hac aequatione continebitur

$$q\left(\frac{du}{dx}\right)+q\left(\frac{dv}{dy}\right)+q\left(\frac{dw}{dz}\right)+u\left(\frac{dq}{dx}\right)+v\left(\frac{dq}{dy}\right)+w\left(\frac{dq}{dz}\right)+\left(\frac{dq}{dt}\right)=0,$$

quae, cum sit $q\left(\frac{du}{dx}\right)+u\left(\frac{dq}{dx}\right)=\left(\frac{d\cdot qu}{dx}\right)$, in hanc contrahitur:

$$\left(\frac{dq}{dt}\right)+\left(\frac{d\cdot qu}{dx}\right)+\left(\frac{d\cdot qv}{dy}\right)+\left(\frac{d\cdot qw}{dz}\right)=0;$$

hic scilicet in differentiatione ipsius qu sola x , ipsius qv sola y et ipsius qw sola z ut variabilis tractari debet.

COROLLARIUM 1

23[a]. Si ergo u , v et w fuerint functiones quatuor variabilium x , y , z et t datae, aequatio inventa indolem functionis q indicabit; quae autem quemadmodum inde definiri debeat, haud patet.

COROLLARIUM 2

24. Sin autem detur densitas q cum duabus celeritatibus u et v , quantitas $\left(\frac{dq}{dt}\right)+\left(\frac{d\cdot qu}{dx}\right)+\left(\frac{d\cdot qv}{dy}\right)$ utpote certa functio ipsarum x , y , z et t erit cognita, qua posita $= Q$ erit $\left(\frac{d\cdot qw}{dz}\right)+Q=0$. Spectetur sola quantitas z variabilis, ac prodibit integrando

$$qw+\int Qdz=\text{Const.}, \text{ ergo } w=\frac{\text{Const.}-\int Qdz}{q}.$$

SCHOLION 1

25. Cum resolutio aequationis inventae:

$$\left(\frac{dq}{dt}\right)+\left(\frac{d\cdot qu}{dx}\right)+\left(\frac{d\cdot qv}{dy}\right)+\left(\frac{d\cdot qw}{dz}\right)=0;$$

sit maximi momenti, observo primo ei satisfieri, si sit

$$q=\Gamma:(x, y, z), \quad qu=\Delta:(t, y, z), \quad qv=\Sigma:(t, x, z), \quad qw=\Pi:(t, x, y),$$

tum enim singula membra seorsim evanescunt, quae est solutio iam latissime patens, cum quatuor habeantur functiones arbitrariae trium variabilium. Adhuc autem generalior solutio

exhiberi potest ope functionis cuiuscunque omnium quatuor variabilium x, y, z et t ; sit enim T huiusmodi functio pro lubitu assumpta praebeatque differentiatam:

$$dT = Fdx + Gdy + Hdz + Idt,$$

quoniam nunc novimus ex natura differentialium esse:

$$\begin{aligned} \left(\frac{dF}{dt}\right) - \left(\frac{dI}{dx}\right) &= 0, \quad \left(\frac{dG}{dt}\right) - \left(\frac{dI}{dy}\right) = 0, \quad \left(\frac{dH}{dt}\right) - \left(\frac{dI}{dz}\right) = 0, \\ \left(\frac{dF}{dy}\right) - \left(\frac{dG}{dx}\right) &= 0, \quad \left(\frac{dF}{dz}\right) - \left(\frac{dH}{dx}\right) = 0, \quad \left(\frac{dG}{dz}\right) - \left(\frac{dH}{dy}\right) = 0, \end{aligned}$$

introducendis sex constantibus $\alpha, \beta, \gamma, \delta, \varepsilon, \zeta$ etiam sequentes valores satisfacereprehenduntur:

$$\begin{aligned} q &= \alpha F + \beta G + \gamma H + \Gamma : (x, y, z) \\ qu &= -\alpha I + \delta G + \varepsilon H + \Delta : (t, y, z) \\ qv &= -\beta I + \varepsilon F - \zeta H + \Sigma : (t, x, y) \\ qw &= -\gamma I + \varepsilon F + \zeta G + H : (t, x, y) \end{aligned}$$

neque tamen asseverare licet hanc solutionem ita esse generalem, ut omnes casus possibiles in ea contineantur.

SCHOLION 2

26. Si fluidum ita sit homogeneum, ut eius densitas sit semper et ubique eadem, relatio inter ternas celeritates u, v et w ita determinatur, ut esse debeat:

$$\left(\frac{du}{dx}\right) + \left(\frac{dv}{dy}\right) + \left(\frac{dw}{dz}\right) = 0.$$

cui statim satisfaciunt hi quoque valores:

$$u = \Delta : (t, y, z), \quad v = \Sigma : (t, x, z), \quad w = \Pi : (t, x, y).$$

Deinde vero etiam generalius introducta functione T , ut sit

$$dT = Fdx + Gdy + Hdz + Idt,$$

erit

$$u = -\delta G - \varepsilon H + \Delta : (t, y, z)$$

$$v = +\delta F - \zeta H + \Sigma : (t, x, z)$$

$$w = +\varepsilon F + \zeta G + \Pi : (t, x, y)$$

in superiori scilicet solutione ponendo $\alpha = 0$, $\beta = 0$, $\gamma = 0$. Hic autem observo non opus esse, ut quantitates δ , ε , et ζ sint constantes, sed etiam variables sumi posse, dum sit

$$\left(\frac{d\delta}{dx}\right) - \left(\frac{d\zeta}{dz}\right) = 0, \quad \left(\frac{d\delta}{dy}\right) + \left(\frac{d\varepsilon}{dz}\right) = 0 \quad \text{et} \quad \left(\frac{d\varepsilon}{dx}\right) + \left(\frac{d\zeta}{dy}\right) = 0,$$

hoc est dum haec formula $\zeta dx - \varepsilon dy + \delta dz$ sit integrabilis. Hinc praeter functionem arbitrariam T adhuc aliam introducere licet V , ut sit

$$dV = Kdx + Ldy + Mdz + Ndt,$$

atque satisfacient hi valores multo generaliores:

$$u = HL - GM + \Delta : (t, y, z)$$

$$v = FM - HK + \Sigma : (t, x, z)$$

$$w = GK - FL + \Pi : (t, x, y).$$

SCHOLION 3

27. Eodem modo etiam in genere pro densitate variabili q solutionem magis universalem reddere licet, introducendis duabus functionibus arbitrariis T et V quatuor variabilium x , y , z et t . Positis enim earum differentialibus:

$$dT = Fdx + Gdy + Hdz + Idt$$

et

$$dV = Kdx + Ldy + Mdz + Ndt$$

conditioni requisitae sequentes satisfacient valores:

$$q = (G+H)K + (H-F)L - (F+G)M + \Gamma : (x, y, z)$$

$$qu = (H+I)L + (I-G)M - (G+H)N + \Delta L : (t, y, z)$$

$$qv = (I+F)M + (F-H)N - (H+I)K + \Xi : (t, x, z)$$

$$qw = (F+G)N + (G-I)K - (I+F)L + \Pi : (t, x, y) .$$

Tum vero etiam duae pluresve huiusmodi formae invicem coniungi possunt, at hoc modo solutio non generalior fieri est censenda; quia, si alia functio pro T sumta veluti T' cum

eadem V coniungatur et valores inde oriundi ad hos respective addantur, eadem prodit solutio, ac si statim pro T sumta fuisset functio $T + T'$, quod idem de altera V est intelligendum, quoniam commutationem admittunt.

CAPUT II

PRINCIPIA MOTUS FLUIDORUM A VIRIBUS QUIBUSCUNQUE SOLLICITATORUM

PROBLEMA 22

28. Si fluidum a viribus quibuscunque sollicitetur et pressio in singulis punctis ut cognita spectetur, investigare vires acceleratrices, quibus singula elementa ad motum impelluntur.

SOLUTIO

Positis (Fig. 25) pro puncto Z coordinatis orthogonalibus $OX = x$, $XY = y$, $YZ = z$ elemento fluidi iam circa Z versanti tribuatur figura parallelepipedo rectanguli $ZLMN zlmn$ differentialibus coordinatarum $ZL = dx$, $ZM = dy$ et $Zz = dz$ contenti, cuius ergo volumen erit $= dx dy dz$, ac si q denotet densitatem in Z , eius massa fit $= q dx dy dz$. Nunc primo consideremus vires gravitati similes in punctum Z agentes, quas cum semper secundum directiones axium OA , OB , OC resolvere liceat, sint istae vires acceleratrices secundum OA seu $ZL = P$, secundum OB seu $ZM = Q$, secundum OC seu $Zz = R$, a quibus ergo elemento fluidi accelerationes secundum easdem directiones inducentur, ad quod quidem non erat necesse elemento certam figuram tribuisse. Verum haec figura maxime est idonea ad vires acceleratrices ex pressionibus natas eliciendas. Sit igitur pro hoc tempore altitudo pressioni in Z debita $= p$, quae ut functio quatuor variabilium x , y , z et t spectari debet: ex cuius indole pressionibus in singulis angulis parallelepipedo definiri poterunt, ut sequitur

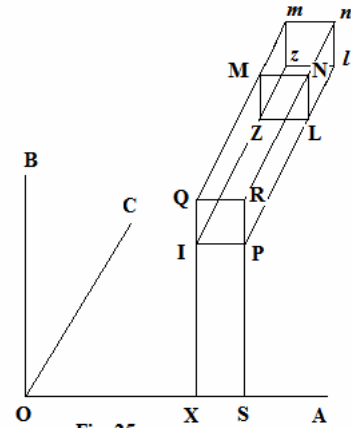

Fig. 25

In puncto	pressio	In puncto	pressio
Z	p	z	$p + dz \left(\frac{dp}{dz} \right)$
L	$p + dx \left(\frac{dp}{dx} \right)$	l	$p + dx \left(\frac{dp}{dx} \right) + dz \left(\frac{dp}{dz} \right)$
M	$p + dy \left(\frac{dp}{dy} \right)$	m	$p + dy \left(\frac{dp}{dy} \right) + dz \left(\frac{dp}{dz} \right)$
N	$p + dx \left(\frac{dp}{dx} \right) + dy \left(\frac{dp}{dy} \right)$	n	$p + dx \left(\frac{dp}{dx} \right) + dy \left(\frac{dp}{dy} \right) + dz \left(\frac{dp}{dz} \right)$

quae pressiones in singulas hedras normaliter agunt. Consideremus binas hedras oppositas $ZM zm$ et $LN ln$ atque manifestum est pressiones, quas hedra $LNln$ in singulis punctis sustinet, superare pressiones hedrae $ZM zm$ in punctis oppositis eadem pressione elementari $dx \left(\frac{dp}{dx} \right)$, qui excessus solus in computum venit. Sustinet ergo hedra $LNln$ pressionem altitudini $dx \left(\frac{dp}{dx} \right)$ debitam; unde, cum huius hedrae area sit $= dydz$, tota pressio aequatur ponderi voluminis $dx dy dz \left(\frac{dp}{dx} \right)$, si scilicet materia homogenea, cuius densitas $= 1$, repletum concipiatur: et huius vis directio, quia in hedram est normalis, erit parallela axi AO . Quare nostrum parallelepipedum, cuius massa $= q dx dy dz$, urgetur secundum directionem AO vi motrice $= dx dy dz \left(\frac{dp}{dx} \right)$, quae ergo per massam divisa praebet vim acceleratricem $= \frac{1}{q} \left(\frac{dp}{dx} \right)$; simili ratiocinio colligitur vis acceleratrix, qua nostrum parallelepipedum secundum directionem BO urgetur, $= \frac{1}{q} \left(\frac{dp}{dy} \right)$, et secundum directionem $CO = \frac{1}{q} \left(\frac{dp}{dz} \right)$. Cum igitur hae vires sint contrariae iis, quibus fluidum sollicitari assumimus, elementum fluidi in Z versans sequentes tres sustinet vires acceleratrices

$$\text{secundum directionem } OA = P - \frac{1}{q} \left(\frac{dp}{dx} \right)$$

$$\text{secundum directionem } OB = Q - \frac{1}{q} \left(\frac{dp}{dy} \right)$$

$$\text{secundum directionem } OC = R - \frac{1}{q} \left(\frac{dp}{dz} \right).$$

In quibus utique omnes vires, quibus fluidi elementa urgeri possunt, comprehenduntur. Etiam si enim usquam fluidum extrinsecus ope pistilli trudatur, hinc alia vis in elementa non propagatur, nisi per pressionem p , cuius hic iam rationem habuimus.

COROLLARIUM 1

29. Quarumcunque ergo virium actioni fluidum fuerit expositum, si modo pressio in singulis eius elementis ut cognita spectetur, facile hinc vires acceleratrices, quas singula fluidi elementa sustinent, assignantur.

COROLLARIUM 2

30. Altitudo autem p pressionem indicans ita in calculum ingreditur, quatenus est functio ternarum coordinatarum x, y et z : siquidem in hac virium determinatione tempus t constans assumitur.

COROLLARIUM 3

30. In viribus acceleratricibus ex pressione natis etiam densitas elementi fluidi q in computum ducitur, cuius in sollicitationibus P , Q , R nulla habetur ratio, quia hae vires elementa sive densiora sive rariora perinde accelerant.

SCHOLION 1

31. Quia vidimus hedram $LNln$ in singulis punctis eandem pressionem $dx\left(\frac{dp}{dx}\right)$ sustinere, omnium harum virium media directio per centrum inertiae parallelepipedo transibit, propterea quod eius massa utpote infinite parva tanquam homogena spectari potest. Quod cum etiam de binis reliquis pressionibus sit intelligendum et vires P , Q , R gravitati similes per se centro inertiae applicatae sunt censendae, ab his viribus iunctim sumtis parallelepipedo nullus motus gyrotorius imprimetur, interim tamen, quia ob fluiditatem eius figura est mutabilis, fieri potest, ut in motu eius dimensiones varientur, quemadmodum etiam eius volumen, nisi densitas fuerit invariabilis, mutationi est obnoxium. Neque tamen omnis motus gyrotorius hinc penitus excluditur: eatenus enim tantum omnes pressionem $dx\left(\frac{dp}{dx}\right)$, quas hedra $LNln$ sustinet, sunt aequales, quatenus variationes differentiales secundi ordinis hic negligimus, quippe a quibus utique tandem quaedam conversio parallelepipedo oriri potest. Colligere hoc licet ex eo, ubi supra translationem elementi pyramidalis $ZLMN$ (Fig. 23) definivimus: quod cum tempusculo infinite parvo dt in situm $zlmn$ proferatur, tam in quantitate quam situ laterum quaedam mutatio est facta, quae tempore finito etiam finita evadere potest. Verum quicumque hic sit motus, eius natura per principia hic stabilienda determinabitur, neque verendum est hic ullam circumstantiam esse praetermissam, qua motus affici queat.

SCHOLION 2

32. Mirum quoque videri potest, quod hic fluidi elemento figuram parallelepipedo rectanguli tribuimus; cum si alia figura fuisset assumpta, calculus multo difficilior extitisset, hincque dubitare liceat, an ex pressionibus eadem vires acceleratrices eratae fuissent? Verum supra iam ostendimus effectum pressionis non a figura corporis, quod eam sustinet, pendere, sed a solo eius volumine: siquidem corpus aquae submersum ab eius pressione semper pro ratione voluminis sursum urgetur, quaecumque fuerit eius figura. Obiici quidem potest hoc phaenomenon ideo evenire, quod tam aquae densitas quam gravitas ubique sit eadem; dum contra, ubi densitas cum viribus sollicitantibus fuerit variabilis, utique figura corporis submersi in computum est ducenda. Hoc autem dubium prorsus evanescit, statim ac volumen pressiones sustinens infinite parvum concipitur, uti hic fecimus, quoniam in spatiolo infinite parvo omnis diversitas tam in densitate quam viribus sollicitantibus excluditur. Quam ob causam iam tuto affirmare licet, quamcunque fluidi elementum in Z consideratum habuerit figuram, inde nullum discrimen in vires acceleratrices, quas sustinet, influere ideoque eas, quas ex figura parallelepipedo

elicuimus, recte se habere simulque ad omnes alias figuras aequae pertinere: ideo autem hac figura sum usus, quia ea ad calculum expediendum maxime est accommodata. Quin etiam ratio figurae ex conclusionibus inde deductis prorsus excessit, manifesta documenta eas a figura nequaquam pendere.

PROBLEMA 23

33. Si fluidum cuiuscunque naturae a viribus quibuscunque sollicitetur, principia stabilire, ex quibus eius motum determinare liceat.

SOLUTIO

Consideremus (Fig. 22) statum fluidi, in quo tempore quocunque = t elapso versabitur, et constitutis ternis axibus fixis OA , OB , OC inter se normalibus contemplemur fluidi particulam quamcunque in puncto Z , cuius situs ternis coordinatis $OX = x$, $XY = y$, $YZ = z$ determinatur et quae sollicitetur a viribus acceleratricibus P , Q , R secundum directiones Zx , Zy , Zz axibus illis et coordinatis parallelas. Iam ad motum fluidi investigandum statuatur primo densitas particulae nunc in Z versantis = q , quae ergo spectanda est ut functio quatuor variabilium x , y , z et t . Deinde sit nunc pressio in Z debita altitudini = p , quae perpetuo ad materiam uniformem gravem, cuius densitas = 1, est referenda; erit ergo quoque p functio quatuor variabilium x , y , z et t . Tertio quocunque motu nunc particula in Z versans feratur, is resolvatur secundum easdem ternas directiones Zx , Zy , Zz , sitque celeritas secundum $Zx = u$, $Zy = v$ et $Zz = w$, quas celeritates spatiis uno minuto secundo percurrentis exhibeamus, dum etiam tempus t in minutis secundis exprimatur. His positis iam vidimus inter has celeritates et densitatem q hanc relationem determinari, ut sit:

$$\left(\frac{dq}{dt}\right) + \left(\frac{d \cdot qu}{dx}\right) + \left(\frac{d \cdot qv}{dy}\right) + \left(\frac{d \cdot qw}{dz}\right) = 0.$$

Deinde in praecedente problemate invenimus elementum fluidi in Z nunc his viribus acceleratricibus urgeri

$$\text{sec.}Zx = P - \frac{1}{q} \left(\frac{dp}{dx}\right), \quad \text{sec.}Zy = Q - \frac{1}{q} \left(\frac{dp}{dy}\right), \quad \text{sec.}Zz = R - \frac{1}{q} \left(\frac{dp}{dz}\right).$$

Ex ipso autem motu huic elemento tributo in problemati 20 eius accelerationes secundum easdem directiones ita invenimus expressas:

$$\text{secundum } Zx = u \left(\frac{du}{dx} \right) + v \left(\frac{du}{dy} \right) + w \left(\frac{du}{dz} \right) + \left(\frac{du}{dt} \right)$$

$$\text{secundum } Zy = u \left(\frac{dv}{dx} \right) + v \left(\frac{dv}{dy} \right) + w \left(\frac{dv}{dz} \right) + \left(\frac{dv}{dt} \right)$$

$$\text{secundum } Zz = u \left(\frac{dw}{dx} \right) + v \left(\frac{dw}{dy} \right) + w \left(\frac{dw}{dz} \right) + \left(\frac{dw}{dt} \right).$$

Quodsi iam altitudinem, per quam corpus grave uno minuto secundo delabitur, ponamus = g , ut tempus et celeritates secundum praescriptam mensuram exprimantur, quaelibet acceleratio vi acceleratrici in $2g$ ductae est aequanda, unde nanciscimur tres aequationes sequentes:

$$2gP - \frac{2g}{q} \left(\frac{dp}{dx} \right) = u \left(\frac{du}{dx} \right) + v \left(\frac{du}{dy} \right) + w \left(\frac{du}{dz} \right) + \left(\frac{du}{dt} \right)$$

$$2gQ - \frac{2g}{q} \left(\frac{dp}{dy} \right) = u \left(\frac{dv}{dx} \right) + v \left(\frac{dv}{dy} \right) + w \left(\frac{dv}{dz} \right) + \left(\frac{dv}{dt} \right)$$

$$2gR - \frac{2g}{q} \left(\frac{dp}{dz} \right) = u \left(\frac{dw}{dx} \right) + v \left(\frac{dw}{dy} \right) + w \left(\frac{dw}{dz} \right) + \left(\frac{dw}{dt} \right),$$

quae cum illa ex consideratione densitatis nata coniunctae universam motus determinationem continent.

COROLLARIUM 1

34. Totum ergo negotium huc redit, ut pro quantitibus p, q, u, v, w eiusmodi functiones quatuor variabilium x, y, z et t inveniantur, quae his quatuor aequationibus satisfaciant, quod infinitis modis fieri posse cum per se est perspicuum, tum natura rei maxime postulat.

COROLLARIUM 2

35. Cum autem densitas q sit vel constans, vel a pressione p sola vel insuper a calore pendeat, hinc nova oritur conditio aequationibus inventis adiungenda, eaque propterea quaestio magis restringitur.

COROLLARIUM 3

36. Cum igitur densitas q aliunde detur, pro quatuor reliquis incognitis p, q, u, v, w quatuor adepti sumus aequationes, ex quo manifestum est solutionem hic datam esse completam nullamque conditionem esse praetermissam, cuius insuper ratio foret habenda.

SCHOLION

37. In his ergo aequationibus inventis universa Theoria motus fluidorum ita continetur, ut non solum ad omnis generis fluida, sed etiam ad omnes prorsus vires, quibus fluida sollicitari possunt, extendatur. Verum tota haec Theoria ad calculi genus plane novum et adhuc vix libatum devolvitur, cum per integrationem functiones quatuor variabilium x, y, z et t a se invicem non pendendum erui oporteat. Cuiusmodi calculus quantopere sit inusitatus et absconditus, hinc colligere licet, quod universus calculus integralis, quatenus adhuc est excultus, tantum functionum unicae variabilis investigatione consummatur

parumque etiam nunc ea eius pars, quae circa functiones duarum variabilium versatur, sit elaborata, quorsum est referendum problema de cordis vibrantibus maximis difficultatibus involutum. Cum igitur hic adeo functiones quatuor variabilium debeant indagari, facile perspicitur, quanta adhuc calculi subsidia in hoc negotio desiderentur. Imprimis ergo in id est incumbendum, ut aequationes inventas sive ad maiorem simplicitatem sive ad minorem numerum redigamus, quo deinceps earum evolutio facilius suscipi queat. Ac ternae quidem postremae aequationes ita sunt comparatae, ut in unam compingi queant, quae autem vim singularum in se complectatur, quemadmodum in sequenti problemate explicabimus.

PROBLEMA 24

38. Si praeter vires sollicitantes P , Q , R etiam ternae cuiusque puncti celeritates u , v et w cum densitate q ut datae spectentur, pressionem p per unicam aequationem determinare.

SOLUTIO

Trium aequationum, quas in praecedente problemate elicuimus, prima exhibet valorem ipsius $\left(\frac{dp}{dx}\right)$, secunda ipsius $\left(\frac{dp}{dy}\right)$ et tertia ipsius $\left(\frac{dp}{dz}\right)$. Cum igitur p sit functio quatuor variabilium x , y , z et t , si tempus t pro constante habeamus, erit utique:

$$dp = dx\left(\frac{dp}{dx}\right) + dy\left(\frac{dp}{dy}\right) + dz\left(\frac{dp}{dz}\right),$$

unde totam rem ad differentiale absolutum dp perducere poterimus. In hunc finem statuamus brevitatis gratia

$$u\left(\frac{du}{dx}\right) + v\left(\frac{du}{dy}\right) + w\left(\frac{du}{dz}\right) + \left(\frac{du}{dt}\right) = U$$

$$u\left(\frac{dv}{dx}\right) + v\left(\frac{dv}{dy}\right) + w\left(\frac{dv}{dz}\right) + \left(\frac{dv}{dt}\right) = V$$

$$u\left(\frac{dw}{dx}\right) + v\left(\frac{dw}{dy}\right) + w\left(\frac{dw}{dz}\right) + \left(\frac{dw}{dt}\right) = W$$

ut tres aequationes ante inventae fiant:

$$\frac{2g}{q}\left(\frac{dp}{dx}\right) = 2gP - U, \quad \frac{2g}{q}\left(\frac{dp}{dy}\right) = 2gQ - V, \quad \frac{2g}{q}\left(\frac{dp}{dz}\right) = 2gR - W,$$

quarum si prima in dx , secunda in dy et tertia in dz ducatur, ob

$$dx\left(\frac{dp}{dx}\right) + dy\left(\frac{dp}{dy}\right) + dz\left(\frac{dp}{dz}\right) = dp,$$

denotante dp differentiali pressionis p dum tempus t constans habetur, obtinebimus eas addendo hanc aequationem:

$$\frac{2gdp}{q} = 2g(Pdx + Qdy + Rdz) - Udx - Vdy - Wdz,$$

ex qua nunc per integrationem investigari oportet pressionem p . Observandum autem est hanc solam aequationem aequae late patere, ac tres praecedentes iunctim sumtas, easque singulas ita in se complecti, ut ea sine ulla cuiusquam determinationis praetermissione in locum trium illarum aequationum substitui possit. Quodsi enim in genere fuerit

$$dp = Ldx + Mdy + Ndz,$$

haec sola aequatio istas tres in se complectitur

$$\left(\frac{dp}{dx}\right) = L, \quad \left(\frac{dp}{dy}\right) = M \quad \text{et} \quad \left(\frac{dp}{dz}\right) = N,$$

neque his tribus aequationibus plus determinatur, quam illa unica.

COROLLARIUM 1

39. Nunc igitur universa motus fluidorum Theoria in his duabus aequationibus continetur:

$$\text{I.} \quad \left(\frac{dq}{dt}\right) + \left(\frac{d \cdot qu}{dx}\right) + \left(\frac{d \cdot qv}{dy}\right) + \left(\frac{d \cdot qw}{dz}\right) = 0$$

$$\text{II.} \quad \frac{2gdp}{q} = 2g(Pdx + Qdy + Rdz) - Udx - Vdy - Wdz,$$

quibus autem insuper relatio inter densitatem q et pressionem p , quam natura fluidi postulat, adiungi debet.

COROLLARIUM 2

40. In posteriori harum aequationum tempus t constans assumitur, unde absoluta integratione in valorem ipsius p loco constantis ingrediatur functio quaecunque arbitraria temporis t : quemadmodum rei natura postulat, quia per vires externas pro lubitu quovis momento pressionem internam p mutari possunt.

COROLLARIUM 3

41. Si in posteriori aequatione quantitates U , V et W ut functiones datae ipsarum x , y et z spectentur, eas ita comparatas esse oportet, ut aequatio integrationem admittat; nisi enim hoc eveniat, eiusmodi motus plane pro impossibili est habendus.

SCHOLION 1

42. Iam saepius observavimus vires acceleratrices P , Q , R , quae quidem in mundo reperiuntur, semper ita esse comparatas, ut formula differentialis $Pdx + Qdy + Rdz$ integrationem admittat, cuius integrale est id, quod actionis quantitatem vocare licet. Quodsi ergo haec actio littera S indicetur, secunda aequatio hanc induet formam:

$$\frac{2gdp}{q} = 2gdS - Udx - Vdy - Wdz.$$

Quare fiet forma $Udx + Vdy + Wdz$ admittat integrationem eiusque integrale vocetur T , ut sit

$$\frac{2gdp}{q} = 2gdS - dT,$$

ubi iam conditiones integrabilitatis satis sunt manifestae, scilicet si q sit quantitas vel constans vel a sola pressione p pendens, integrale est

$$2g \int \frac{dp}{q} = 2gS - T - \Gamma : t,$$

tum vero si q fuerit quantitas a p et $2gS - T$ utcunque pendens, aequatio pariter pro possibili est habenda, utpote duas tantum variables p et $2gS - T$ involvens; inde vero tam p quam q seorsim certis functionibus quantitatis $2gS - T$ aequabuntur, in quas quidem t instar constantis utcunque ingredi potest. Atque ex hoc casu facile intelligitur ad id, ut nostra secunda aequatio integrationem admittat, absolute requiri, ut eam ope substitutionis cuiuscunque in formam binas tantum variables involventem transmutare liceat.

Quaecunque enim aequationes differentiales inter tres pluresve variables sunt posibles, quod, quibus casibus usu veniat, certa criteria in *Analysi* tradi solent, haec criteria semper eo redeunt, ut ope certae substitutionis eae aequationes ad duas tantum variables reduci queant; quemadmodum in casu ante evoluto fieri videmus.

SCHOLION 2

43. Hac autem hypothesi, qua formulam $Udx + Vdy + Wdz$ integrabilem assumimus, formulae nostrae generali insignem restrictionem attulimus. Videtur quidem adeo triplex determinatio hac conditione invehi, cum ea requiratur, ut sit

$$\left(\frac{dU}{dy}\right) = \left(\frac{dV}{dx}\right), \quad \left(\frac{dU}{dz}\right) = \left(\frac{dW}{dx}\right) \quad \text{et} \quad \left(\frac{dV}{dz}\right) = \left(\frac{dW}{dy}\right),$$

sed observandum est, dum binis harum trium formularum fuerit satisfactum, eo ipso etiam tertiae satisfieri. Ponamus enim relationem inter U , V et W ita esse limitatam, ut binae priores formulae impleantur, ex iisque ulteriori differentiatione elicietur:

$$\left(\frac{ddU}{dydz}\right) = \left(\frac{ddV}{dx dz}\right) = \left(\frac{ddW}{dx dy}\right).$$

Cum igitur hinc sit $\left(\frac{ddV}{dx dz}\right) = \left(\frac{ddW}{dx dy}\right)$, haec aequatio utique iam tertiam illam formulam

$\left(\frac{dV}{dz}\right) = \left(\frac{dW}{dy}\right)$ in se complectitur. Ex quo saltem nostram aequationem generalem duplici

determinatione restrinximus. Tum vero etiam perpendendum est has quantitates U , V et W ob primam aequationem generalem etiam a densitate q pendere, ita ut nobis non amplius liberum sit eiusmodi conditiones fingere, siquidem quantitas q etiam seorsim in alteram aequationem ingreditur. Interim tamen hoc certum est, quoscunque valores pro quantitatibus p , q , u , v , w excogitare licuerit, quibus utrique aequationi generali satisfiat, iis motum quendam possibilem exhiberi, si modo eiusmodi fluidum existat, cuius densitas ratione pressionis fictioni illi conveniat. Primam autem aequationem generalem, in quam neque vires P , Q , R ingrediuntur neque pressio, sine respectu ad alteram tractare licet: eius autem integrationem adeo completam reperire contigit, quam in sequenti problemate sum expositurus.

PROBLEMA 25

44. *Aequationis primae pro motu fluidorum inventae :*

$$\left(\frac{d \cdot qu}{dx}\right) + \left(\frac{d \cdot qv}{dy}\right) + \left(\frac{d \cdot qw}{dz}\right) + \left(\frac{dq}{dt}\right) = 0$$

integrale completum investigare.

SOLUTIO

Quaestio ergo huc redit, ut huiusmodi aequatio generalissime resolvatur

$$\left(\frac{dP}{dx}\right) + \left(\frac{dQ}{dy}\right) + \left(\frac{dR}{dz}\right) + \left(\frac{dS}{dt}\right) = 0$$

seu ut pro quatuor quantitatibus P , Q , R , S in genere eiusmodi functiones quatuor variabilium x , y , z et t assignentur, quae non solum huic aequationi satisfiant, sed etiam omnes omnino solutiones in se complectantur. Quem scopum quo tutius ac certius attingamus, a casibus simplicioribus incipiendo successive ad hunc propositum ascendamus. Ac primo quidem, si unica habeatur variabilis x et aequatio unico constet termino $\left(\frac{dP}{dx}\right) = 0$, integrale completum utique est $P = \text{Const.}$

Nunc duae admittantur variables x et y , et integranda sit haec aequatio

$$\left(\frac{dP}{dx}\right) + \left(\frac{dQ}{dy}\right) = 0$$

Hoc in genere praestabitur sumendo pro arbitrio functionem quamcunque binarum variabilium x et y , quae sit O , qua differentiatia fiat $dO = Kdx + Ldy$: ac manifestum est illam aequationem complete integrari his functionibus:

$$P = L + \Gamma : y \quad \text{et} \quad Q = -K + \Delta : x.$$

Statuantur tertio tres variables x , y , z , ut integrari debeat haec aequatio

$$\left(\frac{dP}{dx}\right) + \left(\frac{dQ}{dy}\right) + \left(\frac{dR}{dz}\right) = 0$$

ac supra (paragrapho 25) vidimus ad hoc praestandum pro lubitu duas functiones trium variabilium x , y et z assumi posse, quae si fuerint O et o ex earumque differentiatione prodeat

$$dO = Kdx + Ldy + Mdz \quad \text{et} \quad do = kdx + ldy + mdz,$$

solutio generalis erit:

$$P = Lm - Ml + \Gamma : (y, z),$$

$$Q = Mk - Km + \Delta : (x, z), \quad \text{et}$$

$$R = Kl - Lk + \Sigma : (x, y).$$

Quae solutio cum praeter functiones duas O et o pro lubitu assumtas insuper tres complectatur functiones arbitrarias binarum variabilium, utique pro completa est habenda.

Hinc igitur ratio resolvendi ipsam aequationem propositam concluditur, in qua quatuor variables continentur:

$$\left(\frac{dP}{dx}\right) + \left(\frac{dQ}{dy}\right) + \left(\frac{dR}{dz}\right) + \left(\frac{dS}{dt}\right) = 0$$

Hic scilicet tres functiones pro lubitu quatuor variabilium assumantur, O , o , w , quarum differentialia sint:

$$dO = Kdx + Ldy + Mdz + Ndt$$

$$do = kdx + ldy + mdz + ndt$$

$$d\omega = xdx + \lambda dy + \mu dz + vdt,$$

atque hinc functiones quaesitae P , Q , R , S ita definiantur, ut sit

$$P = +Lmv + Mn\lambda + Nl\mu - Lnv - Mlv - Nm\lambda + \Gamma : (y, z, t)$$

$$Q = -Mn\chi - Nk\mu - Kmv + Mkv + Nm\chi + Kn\mu + \Delta : (x, z, t)$$

$$R = +Nk\lambda + Kl\nu + Ln\chi - Nl\chi - Kn\lambda - Lkv + \Sigma : (x, y, t)$$

$$S = -Kl\mu - Lm\chi - Mk\lambda + Km\lambda + Lk\mu + Ml\chi + \Pi : (x, y, z),$$

qui valores cum satisfaciant, ac praeterea secundum progressionis legem tres functiones arbitrarias quatuor variabilium una cum quatuor functionibus ternarum variabilium ibidem pro arbitrio accipiendas involvant, sine dubio integrationem completam constituere sunt censendae.

COROLLARIUM 1

45. Ne multitudo litterarum mentem obruat, loco functionum O , o , w scribamus litteras F , G , H , et ex harum formulis differentialibus solutio problematis nostri ita se habebit:

$$\begin{aligned}
 qu &= \left(\frac{dF}{dy}\right)\left(\frac{dG}{dz}\right)\left(\frac{dH}{dt}\right) + \left(\frac{dF}{dz}\right)\left(\frac{dG}{dt}\right)\left(\frac{dH}{dy}\right) + \left(\frac{dF}{dt}\right)\left(\frac{dG}{dy}\right)\left(\frac{dH}{dz}\right) \\
 &\quad - \left(\frac{dF}{dy}\right)\left(\frac{dG}{dt}\right)\left(\frac{dH}{dz}\right) - \left(\frac{dF}{dz}\right)\left(\frac{dG}{dy}\right)\left(\frac{dH}{dt}\right) - \left(\frac{dF}{dt}\right)\left(\frac{dG}{dz}\right)\left(\frac{dH}{dy}\right) + \Gamma : (y, z, t) \\
 qv &= -\left(\frac{dF}{dz}\right)\left(\frac{dG}{dt}\right)\left(\frac{dH}{dx}\right) - \left(\frac{dF}{dt}\right)\left(\frac{dG}{dx}\right)\left(\frac{dH}{dz}\right) - \left(\frac{dF}{dx}\right)\left(\frac{dG}{dz}\right)\left(\frac{dH}{dt}\right) \\
 &\quad + \left(\frac{dF}{dz}\right)\left(\frac{dG}{dx}\right)\left(\frac{dH}{dt}\right) + \left(\frac{dF}{dt}\right)\left(\frac{dG}{dz}\right)\left(\frac{dH}{dx}\right) + \left(\frac{dF}{dx}\right)\left(\frac{dG}{dt}\right)\left(\frac{dH}{dz}\right) + \Delta : (x, z, t) \\
 qw &= \left(\frac{dF}{dt}\right)\left(\frac{dG}{dx}\right)\left(\frac{dH}{dy}\right) + \left(\frac{dF}{dx}\right)\left(\frac{dG}{dy}\right)\left(\frac{dH}{dt}\right) + \left(\frac{dF}{dy}\right)\left(\frac{dG}{dt}\right)\left(\frac{dH}{dx}\right) \\
 &\quad - \left(\frac{dF}{dt}\right)\left(\frac{dG}{dy}\right)\left(\frac{dH}{dx}\right) - \left(\frac{dF}{dx}\right)\left(\frac{dG}{dt}\right)\left(\frac{dH}{dy}\right) - \left(\frac{dF}{dy}\right)\left(\frac{dG}{dx}\right)\left(\frac{dH}{dt}\right) + \Sigma : (x, y, t) \\
 q &= -\left(\frac{dF}{dx}\right)\left(\frac{dG}{dy}\right)\left(\frac{dH}{dz}\right) - \left(\frac{dF}{dy}\right)\left(\frac{dG}{dz}\right)\left(\frac{dH}{dx}\right) - \left(\frac{dF}{dz}\right)\left(\frac{dG}{dx}\right)\left(\frac{dH}{dy}\right) \\
 &\quad + \left(\frac{dF}{dx}\right)\left(\frac{dG}{dz}\right)\left(\frac{dH}{dy}\right) + \left(\frac{dF}{dy}\right)\left(\frac{dG}{dx}\right)\left(\frac{dH}{dz}\right) + \left(\frac{dF}{dz}\right)\left(\frac{dG}{dy}\right)\left(\frac{dH}{dx}\right) + \Pi : (x, y, z).
 \end{aligned}$$

COROLLARIUM 2

46. Hic non obstante terminorum multitudine facile est legem observare, qua pro singulis valoribus partes combinantur, in prima nempe expressione nusquam occurrit elementum dx , in secunda omittitur dy , in tertia dz et in quarta dt . Tum vero, si in prima loco dy scribitur dx signaque mutantur oritur secunda, sin vero in prima loco dz scribatur dx , oritur tertia: sicque ex quavis data reliquas elicere licet.

COROLLARIUM 3

47. Tum vero etiam in qualibet expressione ea tria membra eodem signo sunt affecta, quae nullum habent factorem communem; quae autem factorem habent communem, diversis signis afficiuntur. Denique in diversis expressionibus, quae membra nullum factorem habent communem, ea diversis signis, quae unicum factorem habent communem, eodem signo, et quae duos factores habent communes, iterum diversis signis sunt affecta.

SCHOLION 1

48. Cuivis autem membro cuiusque expressionis in reliquis expressionibus nonnisi unicum respondet, quod cum eo duos factores datos habet communes, quod cum imprimis notari mereatur, quoniam ei tota demonstratio istius solutionis innititur, id sequenti modo ostenditur. Sumatur ex forma qu membrum $\left(\frac{dF}{dy}\right)\left(\frac{dG}{dz}\right)\left(\frac{dH}{dt}\right)$, pro quo in reliquis quaeri debeat membrum, quod cum eo hos duos factores $\left(\frac{dF}{dy}\right)\left(\frac{dG}{dz}\right)$ habeat communes. Evidens

autem est tale membrum neque in forma qv (quia hic dy excluditur) neque in forma qw (quia hic dz excluditur) occurrere posse: in forma autem q certe reperiri debet, idque unicum signo contrario affectum scilicet $-\left(\frac{dF}{dy}\right)\left(\frac{dG}{dz}\right)\left(\frac{dH}{dx}\right)$, quod simul de quibusvis aliis membris est tenendum. Hoc iam evicto demonstratio nostrae solutionis ita se habet: considerentur tantum duo huiusmodi membra binos factores datos communes habentia, quae pro factoribus communibus $\left(\frac{dF}{dy}\right)\left(\frac{dG}{dz}\right)$ in his formis reperiuntur;

$$qu = \left(\frac{dF}{dy}\right)\left(\frac{dG}{dz}\right)\left(\frac{dH}{dt}\right) + \text{etc.}, \quad q = -\left(\frac{dF}{dy}\right)\left(\frac{dG}{dz}\right)\left(\frac{dH}{dx}\right) + \text{etc.}$$

unde pro aequatione proposita integranda:

$$\left(\frac{d \cdot qu}{dx}\right) + \left(\frac{d \cdot qv}{dy}\right) + \left(\frac{d \cdot qw}{dz}\right) + \left(\frac{dq}{dt}\right) = 0$$

elicimus solos factores diversos differentiendo:

$$\left(\frac{d \cdot qu}{dx}\right) = \left(\frac{dF}{dy}\right)\left(\frac{dG}{dz}\right)\left(\frac{ddH}{dt dx}\right) + \text{etc.}$$

$$\left(\frac{dq}{dt}\right) = -\left(\frac{dF}{dy}\right)\left(\frac{dG}{dz}\right)\left(\frac{ddH}{dt dx}\right) + \text{etc.}$$

ubi haec duo membra se mutuo tollunt. Ex quo intelligitur, si pro qu , qv , qw et q totae expressiones inventae substituantur et singula membra debite differententur, quo pacto singula membra in tres partes evolvuntur, omnes has partes se mutuo destruere debere. Siquidem dum singula membra differentiantur, inde pro ternis factoribus in differentialibus terna nova membra resultant, in quibus unicus tantum factor differentiatur binis reliquis manentibus, unde, quod hic de destructione membri differentiati $\left(\frac{dF}{dy}\right)\left(\frac{dG}{dz}\right)\left(\frac{ddH}{dt dx}\right)$ est ostensum, idem de omnibus plane valere est iudicandum.

SCHOLION 2

49. Ex solutione problematis, dum per gradus ad aequationem propositam sumus progressi, casum, quo fluidi densitas q est constans et prima aequatio ita se habet

$$\left(\frac{du}{dx}\right) + \left(\frac{dv}{dy}\right) + \left(\frac{dw}{dz}\right) = 0,$$

resolvere poterimus, quod eo magis est notandum, quod huius solutionem ex generali, quam dedimus, derivare non licet. Quamquam autem hic tres tantum variables x , y et z considerantur, tamen nihil impedit, quominus in solutione ibi data etiam quartum t introducamus, eam quasi constantem spectando. Sumtis ergo pro lubitu duabus functionibus F , G quatuor variabilium x , y , z et t , ex iis ternae celeritates u , v et w ita determinabuntur, ut sit

$$\begin{aligned} u &= \left(\frac{dF}{dy}\right)\left(\frac{dG}{dz}\right) - \left(\frac{dF}{dz}\right)\left(\frac{dG}{dy}\right) + \Gamma : (y, z, t) \\ v &= \left(\frac{dF}{dz}\right)\left(\frac{dG}{dx}\right) - \left(\frac{dF}{dx}\right)\left(\frac{dG}{dz}\right) + \Delta : (x, z, t) \\ w &= \left(\frac{dF}{dx}\right)\left(\frac{dG}{dy}\right) - \left(\frac{dF}{dy}\right)\left(\frac{dG}{dx}\right) + \Sigma : (x, y, t), \end{aligned}$$

ubi totum momentum iterum in eo est situm, quod quivis membro cuiusque formae in reliquis respondeat aliquod, quod cum eo datum factorem habeat communem et signo contrario sit affectum. Totus autem hic casus, quo densitas fluidi est quantitas constans, meretur, ut seorsim diligentius evolvatur, cui negotio sequens caput est destinatum. Ceterum in usum analyseos hic notasse iuvabit hac methodo etiam similes aequationes, ubi plures variables quam quatuor occurrerent, generaliter resolvi posse; membrorum autem numerus ita increscit, ut nimis prolixum foret saltem casum quinque variabilium evolvere.

CAPUT III

APPLICATIO HORUM PRINCIPIORUM AD FLUIDA EIUSDEM UBIQUE DENSITATIS

PROBLEMA 26

50. Si fluidi densitas ubique et semper sit eadem idque a viribus quibuscunque sollicitetur, eius motum per formulas analyticas determinare.

SOLUTIO

Quae in capite praecedente de motu fluidorum cuiuscunque indolis sunt tradita, ea ad hunc casum referentur, densitatem, quae ibi utcunque variabilis erat posita, constantem ponendo, quae sit b , ita ut habeamus $q = b$.

Hinc prima statim aequatio in hanc formam contrahitur

$$\left(\frac{du}{dx}\right) + \left(\frac{dv}{dy}\right) + \left(\frac{dw}{dz}\right) = 0,$$

quam sumendis duabus functionibus quibuscunque F et G quatuor variabilium x, y, z et t , ita complete integrari vidimus, ut sit

$$\begin{aligned} u &= \left(\frac{dF}{dy}\right)\left(\frac{dG}{dz}\right) - \left(\frac{dF}{dz}\right)\left(\frac{dG}{dy}\right) + \Gamma : (y, z, t) \\ v &= \left(\frac{dF}{dz}\right)\left(\frac{dG}{dx}\right) - \left(\frac{dF}{dx}\right)\left(\frac{dG}{dz}\right) + \Delta : (x, z, t) \\ w &= \left(\frac{dF}{dx}\right)\left(\frac{dG}{dy}\right) - \left(\frac{dF}{dy}\right)\left(\frac{dG}{dx}\right) + \Sigma : (x, y, t), \end{aligned}$$

ubi Γ , Δ , Σ eiusmodi denotant functiones, ut sit

$$\left(\frac{d\Gamma}{dx}\right) = 0, \quad \left(\frac{d\Delta}{dy}\right) = 0, \quad \text{and} \quad \left(\frac{d\Sigma}{dz}\right) = 0.$$

Pro altera aequatione ponamus primo brevitatis gratia

$$u\left(\frac{du}{dx}\right) + v\left(\frac{dv}{dy}\right) + w\left(\frac{dw}{dz}\right) + \left(\frac{du}{dt}\right) = U$$

$$u\left(\frac{dv}{dx}\right) + v\left(\frac{dv}{dy}\right) + w\left(\frac{dv}{dz}\right) + \left(\frac{dv}{dt}\right) = V$$

$$u\left(\frac{dw}{dx}\right) + v\left(\frac{dw}{dy}\right) + w\left(\frac{dw}{dz}\right) + \left(\frac{dw}{dt}\right) = W$$

et ista aequatio hanc habebit formam:

$$\frac{2gdp}{b} = 2g(Pdx + Qdy + Rdz) - Udx - Vdy - Wdz,$$

ubi cum formula $Pdx + Qdy + Rdz$ semper per se sit integrabilis, eius integrali posito $= S$, erit

$$\frac{2gdp}{b} = 2gS - Udx - Vdy - Wdz,$$

in qua aequatione differentiali notetur tempus t constans esse assumtum. Cum igitur ex priori aequatione celeritates u , v , w iam per quatuor variables sint expressae x , y , z et t , ex hac quoque pressio p per easdem variables exhibetur, dum haec aequatio fuerit possibilis, quod fieri nequit, nisi formula $Udx + Vdy + Wdz$ per se integrationem admittat, qua conditione integratio prioris aequationis non mediocriter restringitur. Posito autem isto integrali $= T$ erit

$$\frac{2gp}{b} = 2gS - T + f : t$$

loco constantis functionem quamcunque ipsius t adiiciendo.

COROLLARIUM 1

51. Ex generalissima igitur prioris aequationis integratione ii tantum casus sunt admittendi, quibus simul formula $Udx + Vdy + Wdz$ integrabilis redditur: quae conditio cum duas determinaciones postulet, functiones illae generales F, G et Γ, Δ, Σ duplicem restrictionem exigunt.

COROLLARIUM 2

52. Pro celeritatibus ergo ternis u , v , w eiusmodi functiones quatuor variabilium x , y , z et t investigari oportet, ut primo sit

$$\left(\frac{du}{dx}\right) + \left(\frac{dv}{dy}\right) + \left(\frac{dw}{dz}\right) = 0,$$

tum vero insuper his formulis est satisfaciendum

$$\left(\frac{dU}{dy}\right) = \left(\frac{dV}{dx}\right), \quad \left(\frac{dU}{dz}\right) = \left(\frac{dW}{dx}\right) \quad \text{et} \quad \left(\frac{dV}{dz}\right) = \left(\frac{dW}{dy}\right),$$

quarum quidem trium posteriorum binae tertiam in se involvunt, ita ut omnino tres conditiones habeantur.

SCHOLION

53. Prior ergo integratio, etsi in genere successit, vix tamen quicquam affert subsidii ad problema propositum resolvendum, quoniam determinatio earum functionum, quas pro ternis celeritatibus u , v et w invenimus, ut formula: $Udx + Vdy + Wdz$ integrabilis evadat, ne minimum quidem sublevatur. Ac temerarium certe foret in tam ardua investigatione facilem resolutionem sperare, cum adeo determinatio motus corporum solidorum maximis sit difficultatibus subiecta. Etsi enim pro his corporibus evolutis casus, quo nullae adsunt vires sollicitantes, tandem feliciter est effecta, tamen nullum plane est dubium, quin motus fluidorum multo magis sit absconditus. Ex quo investigationes eo dirigi conveniet, ut saltem in plures casus particulares inquiramus, quibus motus fluidorum definire liceat. Ac primo quidem motus ille sibi parallelus se offert, quo fluidum perinde ac corpus solidum progreditur, quem idcirco accuratius perpendisse et ex nostris formulis derivasse haud parum iuvabit: totum vero negotium haud mediocriter illustrabitur, si ante casum, quo ternae celeritates plane evanescent, examini subiiciamus; etsi enim sic omnis motus tollitur et res ad aequilibrium perducitur, tamen, quoniam pressio variabilis esse potest, nonnulla hic observanda occurrent, quae in sequentibus utilitate non carebunt.

PROBLEMA 27

54. *Si cuiusque fluidi elementi ternae celeritates u , v , w evanescant, vires autem quaecunque fluidum sollicitent litteris P , Q , R indicatae, quoniam fluidum inquiete permanere sumitur, pressionem fluidi tam in singulis elementis, quam ad quodvis tempus t definire.*

SOLUTIO

Statim apparet hanc hypothesin $u = 0$, $v = 0$, $w = 0$ primae aequationi

$$\left(\frac{du}{dx}\right) + \left(\frac{dv}{dy}\right) + \left(\frac{dw}{dz}\right) = 0,$$

satisfacere. Tum vero ob $U = 0$, $V = 0$, $W = 0$ altera aequatio hanc induit formam:

$$\frac{dp}{b} = Pdx + Qdy + Rdz,$$

ex qua perspicuum est hypothesin quietis ne locum quidem habere posse, nisi vires P, Q, R ita sint comparatae, ut formula $Pdx+Qdy+Rdz$ integrationem admittat. Sit ergo eius integrale $= S$, ut sit $dp = bdS$, et quia tempus t constans est assumtum, integrale completum erit $p = bS + \Gamma : t$ loco scilicet constantis functionem quamcunque temporis t adiiciendo. Pro eodem ergo momento pressio per totam fluidi massam unice pendet a quantitate S , ita ut in stratis aequilibratis, per quae S eundem ubique habet valorem, pressio sit aequalis, quemadmodum in prima sectione de aequilibrio est ostensum. Nunc autem insuper patet, quod ibi non est annotatum, fieri posse, ut in eodem puncto Z successu temporis pressio quomodocunque varietur. Quod etiam cum natura quaestionis mirifice consentit: vasi enim fluidum inclusum esse concipiatur, in quo ope emboli vi quacunquē urgeatur, sicque dum nullam compressionem patitur, sine dubio erit in aequilibrio. Verum hic status aequilibrii non turbabitur, etiamsi vis embolum adigens continuo immutetur sive lege quacunquē sive etiam sine ulla lege, at hinc pressio in fluido continuo quoque immutabitur. Quare cum nostra solutio omnes casus possibiles quietis in se complecti debeat, ratio est manifesta, cur in expressionem pro p inventam functio quaecunquē temporis sit ingressa.

COROLLARIUM 1

55. Ista igitur functio temporis t quovis casu ex variatione virium, quibus embolus impellitur, determinari debet: quae si fuerit arbitraria nullique legi adstricta, haec functio quoque ad genus earum, quas discontinuas vocavi, est referenda: unde necessitas huiusmodi functionum in Analyysi multo clarius elucet.

COROLLARIUM 2

56. Quodsi ergo ad datum tempus pressio in puncto quocunquē fuerit cognita, pro eodem momento in omnibus aliis punctis pressio assignari poterit, quippe quae a sola quantitate S pendeat. Ab his autem pressionibus neque praecedentes neque sequentes ullo modo pendent.

SCHOLION

57. Dum hic fluidum vasi inclusum et ope emboli vi quacunquē urgeri concipitur, per se intelligitur, nisi vas in suo loco sit affixum, id quovis momento talibus viribus sustineri debere, quae ei in quiete continendo sufficiant; alioquin casus cum hypothesi assumpta non conveniret. At vires istae externae aequae parum atque ea, qua embolus adigitur, in formulas nostras differentiales ingrediuntur, quoniam directe motum particularum fluidi non afficiunt, dum singulae tantum a viribus naturalibus P, Q, R et pressione sollicitantur: verum integratione demum peracta functiones illae arbitrarie per integrationes in calculum introductae ad illas vires externas omnesque alias circumstantias accommodari debent. Vires externae autem duplicis sunt generis, quarum alterae solum vas tanquam corpus solidum urgent neque ipsum fluidum afficiunt, alterae vero quasi embolo applicatae simul fluidum premunt et vas ipsum perinde atque illae sollicitant. Praeterea vero etiam vas ipsum a viribus P, Q, R eandem sustinet vim, ac si cum fluido unum corpus solidum

constitueret earumque actioni esset expositum; ex quo facile intelligere licet, quantis viribus opus sit ad vas inquiete continendum, ne cum vase etiam fluidum de statu quietis deturbetur.

PROBLEMA 28

58. Si cuiusque fluidi puncti Z ternae celeritates u, v, w fuerint constantes, ita ut singula elementa motu uniformi secundum eandem directionem ferantur, dum a viribus acceleratricibus quibuscunque sollicitantur, pressiones fluidi ubique et pro omni tempore investigare.

SOLUTIO

Tota ergo fluidi massa perinde movetur, ac corpus solidum; si ergo vasi concipiatur inclusum, hoc vas cum fluido uniformiter in directum movebitur, cuiusmodi motus utique obtineri potest, non obstantibus viribus P, Q, R fluidum urgentibus, dum eiusmodi vires vasi extrinsecus applicantur, quae quovis momento cum illis in aequilibrio constituentur. Tum vero, si inter has vires quaequam ope pistilli in ipsum fluidum agat, quoniam ea pro lubitu variari potest, etiam quovis momento pressiones in fluido ad arbitrium mutari poterunt, id quod calculus ex solutione deductus declarare debet. Nam ob celeritates ternas constantes ponatur $u = \alpha, v = \beta, w = \gamma$, ac primae quidem aequationi sponte satisfit. Tum vero fiet $U = 0, V = 0, W = 0$, ex quo ob

$$Pdx + Qdy + Rdz = dS$$

erit ut ante

$$dp = b dS \text{ et } p = bS + f : t.$$

Quovis ergo momento per totum vas pressio erit $p = bS + C$, sicque ab actione virium S eodem modo pendet, quo in casu quietis, diversis autem temporibus haec pressio pro lubitu variari potest, prorsus uti natura quaestionis postulat.

SCHOLION

59. Hic casus ex praecedente, quo tota fluidi massa in quiete perseverabat, deduci potuisset secundum principium in Mechanica receptum, quod in motu corporum omnia manent eadem, si totum eorum systema insuper uniformiter in directum proferri concipiatur. Verum hic ob vires sollicitantes P, Q, R aliquod discrimen accedit; in quiete enim quodlibet fluidi elementum perpetuo eandem sollicitationem sustinet, dum autem fluidi massa progreditur et idem elementum alia atque alia loca percurrit, evenire utique potest, ut successive ab aliis atque aliis viribus sollicitetur, siquidem hae vires a loco

pendent, ut plerumque fieri solet. Cum igitur pro eodem fluidi elemento hic quantitas S sit variabilis, quae in casu quietis manebat constans, peculiari solutione erat opus. Probe autem tenendum est, nisi vires sollicitantes ita sint comparatae, ut formula $Pdx + Qdy + Rdz$ integrationem admittat, tum talem motum aequae parum locum habere posse ac quietem, quomodocunque etiam vires extrinsecus agentes attemperentur. Si scilicet eiusmodi casus existeret, etiamsi initio motus uniformis in directum fluido fuisset impressus, is tamen nullo modo conservari posset, sed aequabilitas perpetuo turbaretur; hocque adeo casu hypothesis celeritatum constantium contradictionem implicare est censenda. Denique hinc etiam clarius intelligitur omnes circumstantias externas veluti vasis et virium sive vas solum sive etiam fluidum pistillorum ope urgentium in aequationes canonicas motum fluidorum exprimentes non ingredi, sed demum integratione peracta functiones arbitrarias in calculum invectas ad eas accommodari oportere, quae functiones etiam semper ita sunt comparatae, ut omnes plane circumstantias externas in se complectantur.

PROBLEMA 29

60. Si ternae cuiusque puncti celeritates u , v , w per functiones solius temporis t exprimantur, explorare, utrum talis motus existere queat et sub quibus conditionibus, dum fluidi singulae particulae a viribus quibuscunque sollicitantur, tum vero pressionem per totam fluidi massam investigare.

SOLUTIO

Eodem ergo temporis instanti omnia fluidi elementa pari motu in eandem directionem feruntur, et tempore fluente omnibus aequalis mutatio cum celeritatis tum directionis ratione induci statuitur; unde cum singula fluidi elementa easdem perpetua inter se distantias servent, tota massa instar corporis solidi promovebitur, et quia iisdem semper terminis circumscribitur, vasi inclusa una cum vase motu progressivo proferetur, omni scilicet motu gyatorio excluso. Cum igitur u , v et w sint functiones temporis t tantum, primae statim aequationi

$$\left(\frac{du}{dx}\right) + \left(\frac{dv}{dy}\right) + \left(\frac{dw}{dz}\right) = 0,$$

sponte satisfit; deinde pro altera aequatione, ob

$$U = \left(\frac{du}{dt}\right), \quad V = \left(\frac{dv}{dt}\right), \quad W = \left(\frac{dw}{dt}\right)$$

ideoque et has quantitates functiones solius t , habebimus

$$\frac{2gdp}{b} = 2gdS - dx\left(\frac{du}{dt}\right) - dy\left(\frac{dv}{dt}\right) - dz\left(\frac{dw}{dt}\right),$$

in qua tempus t constans assumitur. Quare dum sit formula $dS = Pdx + Qdy + Rdz$ integrabilis, etiam haec aequatio integrationem admittet motusque assumtus

subsistere poterit: fietque

$$\frac{2gp}{b} = 2gS - x\left(\frac{du}{dt}\right) - y\left(\frac{dv}{dt}\right) - z\left(\frac{dw}{dt}\right) + f : t.$$

Dummodo ergo vires extrinsecus tam vas quam fluidum sollicitantes ita fuerint comparatae, ut talem motum in corpore solido producant, etiam fluidum eundem motum recipiet; et quoniam illud infinitis modis fieri potest, siquidem illis viribus semper binas sibi aequales et contrarias insuper adiungere licet, si earum altera simul in fluidum ope pistilli agat, quovis momento pressio in fluido pro arbitrio immutari potest, quae mutatio in functione illa arbitraria $f: t$ continetur. Ex quo manifestum est evenire utique posse, ut massa fluida motu praescripto feratur, et quomodocunque vires externae ad hoc requisitae se habeant, ad quodvis tempus pressionem per totam massam assignare licet, quae hoc casu non solum ab actione S , sed etiam a coordinatis x, y, z pendebit.

COROLLARIUM 1

61. Si igitur fluidum vasi inclusum concipiatur, ut vas eo motu progressivo feratur, quem celeritates u, v, w designant, fluidum respectu vasis quiescet et cum eo quasi corpus solidum constituere poterit spectari.

COROLLARIUM 2

62. Hoc tamen non obstante pressiones in fluido utcunque poterunt esse variables, dum primum ab actione virium S , quae utique a loco pendet, tum vero etiam a ternis variabilibus x, y, z , quae etiam pro eodem fluidi elemento iugiter mutantur, pendent; haecque postrema mutatio a defectu uniformitatis motus oriri est censenda.

COROLLARIUM 3

63. Praeter has autem mutationes, quae tam ab actione virium quam motus inaequalitate proveniunt, pressio variationi cuicumque temporis successu obnoxia esse potest. Interim tamen pro quovis tempore, si in uno loco pressio constet, in omnibus reliquis assignari poterit.

SCHOLION

64. Dum ergo vires sollicitantes P, Q, R ita sint comparatae, ut formula $Pdx + Qdy + Rdz$ integrationem admittat, massa fluida omnes motus progressivos recipere potest, qui in corpora solida cadunt, simodo densitas fluidi fuerit constans nullamque mutationem a viribus sollicitantibus patiat. Utrum vero etiam motu gyatorio perinde ac corpus solidum ferri possit? hinc nondum patet; hancque investigationem in caput sequens reservamus, ubi quidem hoc argumentum generalius pertractabimus; cum enim in corpore solido circa axem fixum gyrante celeritates sint ipsis distantibus ab axe proportionales,

in fluido aliae quoque proportiones locum habere possunt, quia hic nulla necessitas urget, ut singula elementa eodem tempore suas revolutiones absolvant. In hoc autem capite restant eiusmodi casus perpendendi, quibus inter ternas celeritates ratio quaedam constans praescribitur, dum earum quaelibet utcunque variabilis assumitur, cuiusmodi motus, quoniam a motu solidorum maxime abhorret, nostro instituto imprimis dilucidando inserviet.

PROBLEMA 30

65. Si ternae cuiusque puncti celeritates u , v , w ubique et semper constantem inter se servant rationem, conditiones scrutari, sub quibus talis motus existere queat, dum interea singula fluidi elementa a viribus quibuscunque P , Q , R sollicitantur.

SOLUTIO

Quoniam ternae celeritates u , v , w constantem inter se tenent rationem, singula fluidi elementa secundum eandem directionem movebuntur, celeritate utcunque variabili; qui motus utrum et sub quibus conditionibus locum habere posset, investigari oportet. Introducta ergo nova variabili ϑ , quae sit functio quaecunque quatuor quantitatum x , y , z et t , statuamus

$$u = \alpha\vartheta, \quad v = \beta\vartheta \quad \text{et} \quad w = \gamma\vartheta,$$

ut α , β , γ sint quantitates constantes, atque ut primae aequationi satisfiat, oportet sit

$$\alpha \left(\frac{d\vartheta}{dx} \right) + \beta \left(\frac{d\vartheta}{dy} \right) + \gamma \left(\frac{d\vartheta}{dz} \right) = 0.$$

Cum autem sit

$$d\vartheta = dx \left(\frac{d\vartheta}{dx} \right) + dy \left(\frac{d\vartheta}{dy} \right) + dz \left(\frac{d\vartheta}{dz} \right),$$

erit

$$\alpha d\vartheta = -\beta dx \left(\frac{d\vartheta}{dy} \right) - \gamma dx \left(\frac{d\vartheta}{dz} \right) + \alpha dy \left(\frac{d\vartheta}{dx} \right) + \alpha dz \left(\frac{d\vartheta}{dz} \right)$$

seu

$$\alpha d\vartheta = (\alpha dy - \beta dx) \left(\frac{d\vartheta}{dy} \right) + (\alpha dz - \gamma dx) \left(\frac{d\vartheta}{dz} \right),$$

cui aequationi satisfieri intelligitur, simodo ϑ sit functio binarum quantitatum variabilium

$$(\alpha y - \beta x) \text{ et } (\alpha z - \gamma x) \text{ vel harum } \left(\frac{x}{\alpha} - \frac{y}{\beta} \right) \text{ et } \left(\frac{x}{\alpha} - \frac{z}{\gamma} \right),$$

quibus etiam tertia t adiungi potest. Sit enim ϑ functio quaecumque harum trium variabilium

$$\left(\frac{x}{\alpha} - \frac{y}{\beta}\right), \left(\frac{x}{\alpha} - \frac{z}{\gamma}\right) \text{ et } t,$$

quae differentiata praebeat:

$$d\vartheta = L \left(\frac{dx}{\alpha} - \frac{dy}{\beta}\right) + M \left(\frac{dx}{\alpha} - \frac{dz}{\gamma}\right) + Ndt,$$

eritque

$$\left(\frac{d\vartheta}{dx}\right) = \frac{1}{\alpha}L + \frac{1}{\alpha}M, \quad \left(\frac{d\vartheta}{dy}\right) = -\frac{1}{\beta}L \quad \text{et} \quad \left(\frac{d\vartheta}{dz}\right) = -\frac{1}{\gamma}M,$$

unde utique fit

$$\alpha \left(\frac{d\vartheta}{dx}\right) + \beta \left(\frac{d\vartheta}{dy}\right) + \gamma \left(\frac{d\vartheta}{dz}\right) = 0.$$

Tali ergo functione pro ϑ stabilita colligetur:

$$U = \alpha \vartheta \left(\frac{d\vartheta}{dx}\right) + \alpha \beta \vartheta \left(\frac{d\vartheta}{dy}\right) + \alpha \gamma \vartheta \left(\frac{d\vartheta}{dz}\right) + \alpha \left(\frac{d\vartheta}{dt}\right),$$

quae ob

$$\alpha \left(\frac{d\vartheta}{dx}\right) + \beta \left(\frac{d\vartheta}{dy}\right) + \gamma \left(\frac{d\vartheta}{dz}\right) = 0$$

abit in

$$U = \alpha \left(\frac{d\vartheta}{dt}\right)$$

similique modo erit

$$V = \beta \left(\frac{d\vartheta}{dt}\right) \quad \text{et} \quad W = \gamma \left(\frac{d\vartheta}{dt}\right).$$

Quocirca altera aequatio pro motu fluidorum inventa ita se habebit considerando tempus t constans

$$\frac{2gd\rho}{b} = 2gdS - (\alpha dx + \beta dy + \gamma dz) \left(\frac{d\vartheta}{dt}\right),$$

quae, si formula $dS = Pdx + Qdy + Rdz$ sit integrabilis, absolute postulat, ut etiam altera pars

$$(\alpha dx + \beta dy + \gamma dz) \left(\frac{d\vartheta}{dt}\right)$$

integrationem admittat; quod fieri nequit,

nisi $\left(\frac{d\vartheta}{dt}\right)$ sit functio harum duarum quantitatum

$\alpha x + \beta y + \gamma z$ et t , quod cum superiori conditione subsistere nequit,

nisi $\left(\frac{d\vartheta}{dt}\right)$ sit functio solius

temporis t . Quamobrem quantitas ϑ ita esse debet comparata, ut sit

$$\vartheta = \text{funct.} : \left(\left(\frac{x}{\alpha} - \frac{y}{\beta} \right) \text{ et } \left(\frac{x}{\alpha} - \frac{z}{\gamma} \right) \right) + \Gamma : t,$$

ut fiat $\left(\frac{d\vartheta}{dt}\right) = \Gamma' : t$; tum autem reperietur

$$\frac{2gp}{b} = 2gS - (\alpha x + \beta y + \gamma z) \Gamma' : t + \Delta : t$$

existente $\Gamma' : t = \frac{d\Gamma t}{dt}$.

COROLLARIUM 1

66. Elementum ergo fluidi in Z movetur celeritate, quae est

$$= \vartheta \sqrt{\alpha\alpha + \beta\beta + \gamma\gamma},$$

eiusque directio ad axem OA inclinata est angulo, cuius cosinus

$$\frac{\alpha}{\sqrt{\alpha\alpha + \beta\beta + \gamma\gamma}},$$

ad axem OB angulo, cuius cosinus

$$\frac{\beta}{\sqrt{\alpha\alpha + \beta\beta + \gamma\gamma}},$$

et ad axem OC angulo, cuius cosinus

$$\frac{\gamma}{\sqrt{\alpha\alpha + \beta\beta + \gamma\gamma}},$$

COROLLARIUM 2

67. Cum igitur motus directio ubique et semper sit eadem, omnia fluidi elementa secundum lineas rectas inter se parallelas proferuntur. Celeritas autem tam ratione loci quam temporis maxime variabilis esse poterit, dummodo ϑ sit eiusmodi functio, qualem descripsimus.

COROLLARIUM 3

68. Summa autem varietas hic locum invenire potest, cum pro ϑ functionem quamcunque harum duarum quantitatum $\frac{x}{\alpha} - \frac{y}{\beta}$ et $\frac{x}{\alpha} - \frac{z}{\gamma}$ accipere licet, eique insuper functionem temporis quamcunque adiicere.

COROLLARIUM 4

69. Ex superioribus patet litteras U, V, W exprimere accelerationes motus secundum directiones coordinatarum x, y, z , unde si fuerit $\Gamma : t = 0$ ideoque $\left(\frac{d\vartheta}{dt}\right) = 0$, hae accelerationes evanescent, et quodvis elementum uniformiter in directum progredietur.

SCHOLION

70. Hic motus satis similis deprehenditur ei, quo flumina progrediuntur; si enim gravitas sola in fluidum agat deorsum secundum ZY , erit

$$P = 0, \quad Q = 0 \quad \text{et} \quad R = -1 \quad \text{ideoque} \quad S = -z,$$

ac si porro functio a tempore pendens evanescat, ut sit

$$\vartheta = \text{funct.} : \left(\left(\frac{x}{\alpha} - \frac{y}{\beta} \right) \text{ et } \left(\frac{x}{\alpha} - \frac{z}{\gamma} \right) \right) \text{ et } p = b(a - z),$$

sicque pressio in plano horizontali ad altitudinem $z = a$ evanescit. Neque vero necesse est, ut fluidi directio sit horizontalis, sed motus subsistere potest, etiamsi fluidum sive sursum sive deorsum feratur, sive utcunque obliquum teneat cursum, quod quidem difficulter concipi potest, quia fluidum per superficiem summam transire deberet. Verum hic aliud incommodum occurrit, quod in fluido ultra altitudinem a versante pressio evaderet negativa, ideoque fluidi continuitas dissolveretur idque quasi in guttas dispergeretur. Initio autem iam monui haec principia, quae stabilivi, ita continuitati fluidi esse innixa, ut, ubi ea cessaverit, illa non amplius locum habere posse: ex quo eiusmodi casus, ubi fluidum continuum cohaerere desierit, hinc sunt excludendi. De cetero, quando hic motum ut possibilem praedicamus, id semper ita est intelligendum eiusmodi vires externas dari posse, quarum actione ille motus obtineri queat. Verum problema hic tractatum generalius sequenti modo proponi ac resolvi potest.

PROBLEMA 31

71. Si ternae cuiusque fluidi elementi celeritates u, v, w ita sint comparatae, ut sit

$$u = \alpha\vartheta + \Gamma : t, \quad v = \beta\vartheta + \Delta : t \quad \text{et} \quad w = \gamma\vartheta + \Sigma : t,$$

denotante ϑ functionem quamcunque, conditiones scrutari, sub quibus talis motus subsistere potest, dum singula fluidi elementa a viribus quibuscunque P, Q, R

sollicitantur.

SOLUTIO

Hic perinde atque in praecedente problemate prima aequatio generalis postulat, ut φ sit functio harum duarum quantitatum $\frac{x}{\alpha} - \frac{y}{\beta}$ et $\frac{x}{\alpha} - \frac{z}{\gamma}$, neque iam opus est ad eam quampiam functionem temporis t adiici, cum in hypothesis iam tales functiones indefinitae ternis celeritatibus sint adiunctae.

Cum igitur hinc fiat

$$\alpha \left(\frac{d\varphi}{dx} \right) + \beta \left(\frac{d\varphi}{dy} \right) + \gamma \left(\frac{d\varphi}{dz} \right) = 0$$

obtinebitur

$$U = \left(\frac{du}{dt} \right) = \Gamma' : t, \quad V = \Delta' : t \quad \text{et} \quad W = \Sigma' : t$$

ideoque posita virium actione $\int (Pdx + Qdy + Rdz) = S$ aequatio statum pressionis declarans erit

$$\frac{2gp}{b} = 2gS - x\Gamma' : t - y\Delta' : t - z\Sigma' : t + \Pi' : t.$$

COROLLARIUM 1

72. Hoc problema multo latius patet quam praecedens, quod non solum labente tempore in eodem puncto directio motus vehementer variari possit, sed etiam eodem tempore in diversis fluidi elementis diversa inesse possit motus directio.

COROLLARIUM 2

73. Eodem autem tempore, quo functiones $\Gamma : t, \Delta : t, \Sigma : t$ per totam fluidi massam eosdem valores sortiuntur, quoniam φ pendet a loco Z , in diversis punctis non solum celeritas sed etiam directio motus maxime discrepans esse poterit: ubique tamen

$\frac{u}{\alpha} - \frac{v}{\beta}$ et $\frac{u}{\alpha} - \frac{w}{\gamma}$ eosdem obtinebunt valores.

SCHOLION

74. Multum autem hic motus adhuc differt a cursu fluminum; si enim formulas inventas huc accommodare vellemus, primo ut motus in eodem puncto perpetuo prodeat idem, functiones temporis $\Gamma : t, \Delta : t, \Sigma : t$ quantitates constantes denotare deberent, tum autem ob $S = -z$ oriretur $p = b(a - z)$, sicque pressionem in plano quodam horizontali evanescerent. Nullus ergo motus verticalis fluidi particulis tribui posset, quia alioquin fluidum supra superficiem summam esset admittendum, foret ergo $w = 0$ ideoque et $\gamma = 0$ et $\Sigma : t = 0$, unde singula fluidi elementa in planis horizontalibus moverentur neque propterea ulla hic declivitas locum inveniret, quae tamen fluminum proprietates essentialis.

Ex quo investigatio motus fluviorum est res multo altioris indaginis iudicanda. Interim tamen hic exemplum eiusmodi fluvii cernimus, cuius singulae particulae motu horizontali proferuntur, quarum autem directio aequae ac celeritas utcunque sint variables. Hoc tamen non obstante pressio ubique a sola pendeat profunditate eodem plane modo, ac si fluidum stagnaret. Cum autem hoc casu sit $y = 0$, fiet ϑ functio quaecunque harum duarum

quantitatum $\left(\frac{x}{\alpha} - \frac{y}{\beta}\right)$ et z , sicque in eodem plano horizontali quocunque eadem reperietur in

omnibus punctis, ubi $\frac{x}{\alpha} - \frac{y}{\beta}$ eiusdem erit valoris, hoc est in omnibus lineis rectis ad axem

OA inclinatis angulo, cuius tangens $= \frac{\beta}{\alpha}$, quae ergo inter se erunt parallelae: et omnes fluidi particulae in tali recta sitae pari motu ferentur: neque vero secundum hanc ipsam rectam progredientur, cum posito $F: t = m$ et $A: t = n$ eius

celeritates sint futurae $u = \alpha\vartheta + m$ et $v = \beta\vartheta + n$

unde quidem celeritates erunt aequales, sed directiones ab illa recta utcunque declinabunt, nisi sit $m : n = \alpha : \beta$. Dum igitur hoc modo ab ista recta in aliam sibi parallelam transferantur, ubi alia dabitur tam celeritas quam directio, evidens est fieri posse, ut singula fluidi elementa in lineis curvis motu maxime inaequabili deferantur. Unde si via cuiusque particulae in plano horizontali sit definienda ope aequationis inter binas coordinatas x et y , ob

$$dx = dx(\alpha\vartheta + m) \quad \text{et} \quad dy = dt(\beta\vartheta + n)$$

eliminando dt fit

$$\vartheta(\beta dx - \alpha dy) + ndx - mdy = 0.$$

Quia vero hic profunditas z eadem manet, erit ϑ functio ipsius $\frac{x}{\alpha} - \frac{y}{\beta}$ seu $\beta x - \alpha y$

$\{Jx - Xy$, pro qua scribendo $\Theta' : (\beta x - \alpha y)$ fit

$$nx - my + \Theta' : (\beta x - \alpha y) = \text{Const.}$$

$$nx - my + \Theta(\beta x - \alpha y) = \text{Const.}$$

Functio ergo Θ ita accipi potest, ut data curva prodeat, quae ad externas particulas in hoc plano relatas figuram ripae flumen terminantis repraesentabit sicque ad singulas profunditates ad arbitrium figura ripae ideoque totius alvei cavitas formari poterit.